

| | |
|--------------------------|--------------------------|
| Name: _____ | Date: _____ Event: _____ |
| City: _____ State: _____ | Track: _____ |

Track Conditions: Indoor Outdoor Tight Open Smooth Rough Hard Packed Loose/Loamy Blue Groove Dry Wet Dusty Grass Astro Turf Low Bite Med Bite High Bite Other _____

Front Suspension

Toe: _____
 Ride Height: _____
 Camber: _____
 Caster: 0° 5° Trail: 2mm 4mm
 Kick Angle: 20° 25° 30°
 Sway Bar: _____
 Oil: _____
 Piston: _____
 Spring: Standard Low Freq. Color: _____
 Front Pivot: Aluminum Plastic HRC
 Kick Shim: Brass Plastic
 Shock Limiters: _____
 Shock Location: _____
 Bump Steer Ball Stud: Standard Low Mount
 Bumper Steer Spacers: _____
 Ackermann Ball Stud: Standard Low Mount
 Ackermann Spacers: _____
 Camber Link: _____

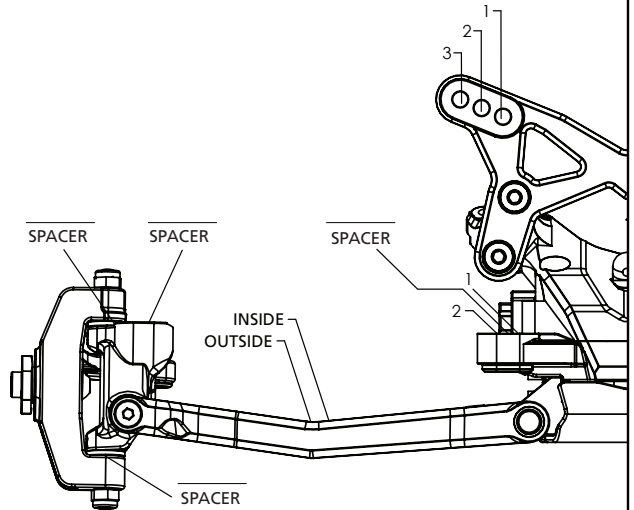

Notes: _____

Rear Suspension

Chassis Configuration: Rear Motor Mid Motor
 Toe: _____
 Anti-Squat: _____
 Roll Center: Low Roll Center (LRC) High Roll Center (HRC)
 Ride Height: _____
 Camber: _____
 Rear Hub Spacing: _____
 Hex Width: _____
 Sway Bar: _____
 Oil: _____
 Piston: _____
 Spring: Standard Low Freq. Color: _____
 Shock Limiters: _____
 Camber Link: _____
 Shock Locations: _____
 Wing/Wickerbill: _____
 Battery Position: _____

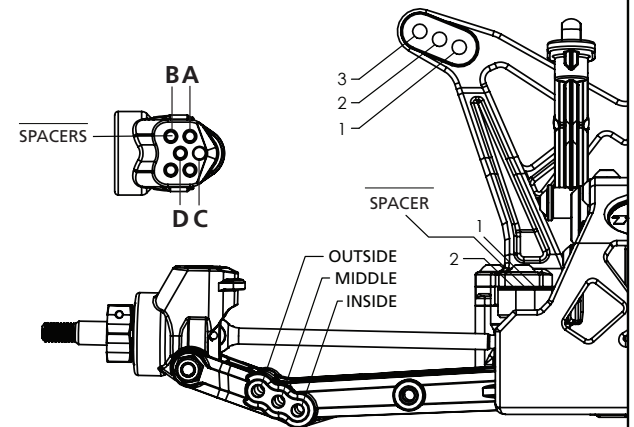

Electronics

| | |
|-------------------------|----------------------------|
| Radio: _____ | Timing Advance: _____ |
| Servo: _____ | Throttle/Brake Expo: _____ |
| ESC: _____ | Servo Expo: _____ |
| Initial Brake: _____ | Throttle/Brake EPA: _____ |
| Drag Brake: _____ | Motor: _____ |
| Throttle Profile: _____ | Pinion: _____ Spur: _____ |
| | Battery: _____ |

| | | | | | | | | |
|---|--|--|----------|--------|----------|-------|-------|-------|
| <p>Weight Placement (Mark with "X")</p> <p>Weight of each piece _____ oz./g</p> | <p>Tires Front: _____ Rear: _____ Notes: _____</p> | <table border="0" style="width:100%;"> <tr> <td style="text-align: center;">Compound</td> <td style="text-align: center;">Insert</td> <td style="text-align: center;">Additive</td> </tr> <tr> <td>_____</td> <td>_____</td> <td>_____</td> </tr> </table> | Compound | Insert | Additive | _____ | _____ | _____ |
| Compound | Insert | Additive | | | | | | |
| _____ | _____ | _____ | | | | | | |