

Name: Lozan Whiting
 Date: 8/3/09
 Track: GLC

Track conditions

Size: Open Med. Tight
 Traction: High Med. Low
 Surface: Smooth Med. Bumpy

Front suspension

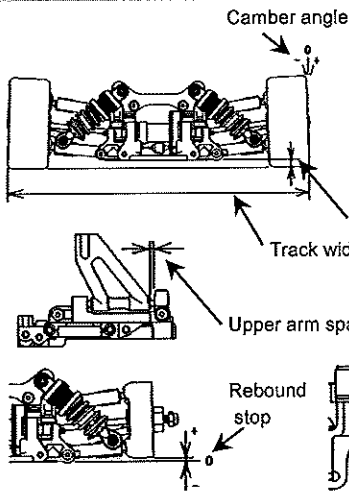

Track width 198 mm
 Ride height 4.5 mm
 Camber angle 2.5 °
 Upper arm spacer 1 mm
 Toe angle -1 °
 Rebound stop 0 mm

Ride height Bump stop
 None Use
 Upper arm position 1 mm
 Anti-roll bar
 Upright T0138-B T0164
 Upper arm position 1 mm

Front shock

Piston Stock
 Oil # 500
 Spring Lt. Blue
 Sock position

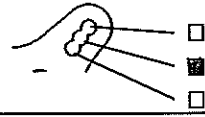

Front Diff.

One way
 Gear diff.
 Oil # 100K
 Solid

Steering ackerman

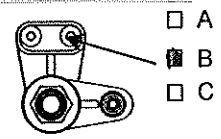

Rear suspension

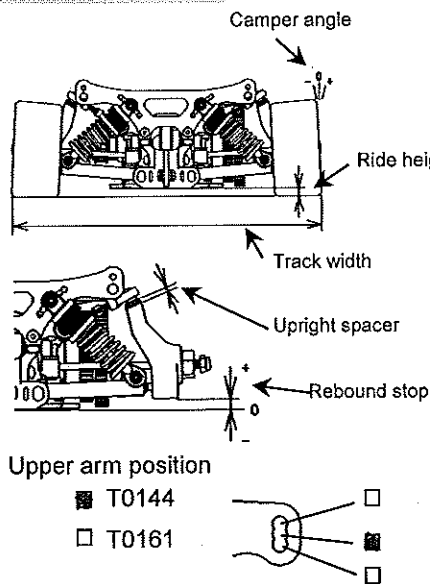

Track width 200 mm
 Ride height 5.5 mm
 Camber angle 5L - 4.5R °
 Toe angle 3 °
 Rebound stop 5 mm

Ride height Bump stop
 None Use
 Lower arm position
 Upright spacer 3.5 mm
 Anti-roll bar Wire ϕ 2.5
 Adjustable(T0162)
 Wheel Hub Spacer 0 mm

Rear Shock

Piston Stock
 Oil # 500
 Spring Lt. Blue
 Shock position

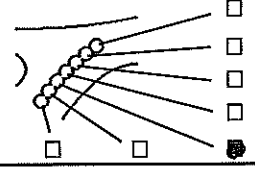

Rear Diff.

Oil # 50K

Engine Type Nova Rossi 353-09
 Gasket mm Muffler Max 2649
 Plug 7 Fuel Wexks 30%

Clutch

Clutch shoe Black Gray Yellow
 Centrifugal shoe Drilled 4mm
 Spring MSR
 Clutch bell clearance .2 mm
 Spring adj. Nut position 9.85 mm

Tire <Front> Type BSR 38
 Dia.(start) 58 L IR 58
 Dia.(finish) 56.5 L IR 56.5
 <Rear> Type BSR 42
 Dia.(start) 60.5 L IR 60.5
 Dia.(finish) 58 L IR 58

Brake pad

Black Other

Body Type Stratus 3.1
 Wing _____

Drive ratio

Gear ratio Side pulley
 1st. 171.59 24T
 2nd. 231.53 25T

Result
 Race time / Lap _____
 Best lap (1Lap) _____

Comments:

We should have started with 59mm rears and 57 fronts. The cars were very good. We should have pushed harder for the first half of the race!