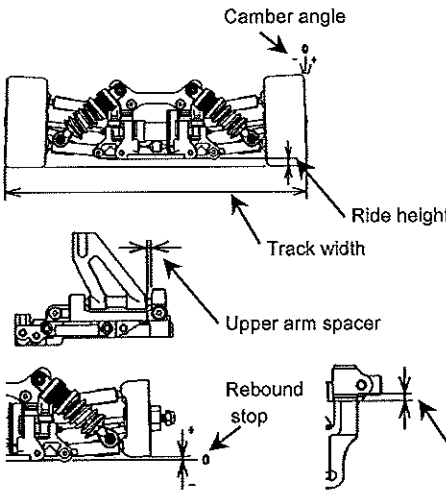

Name: Jeff Whiting
 Date: 3/29/09
 Track: Texas Biggie

Track conditions

Size: Open Med. Tight
 Traction: High Med. Low
 Surface: Smooth Med. Bumpy

Front suspension

Track width 199 mm
 Ride height 7 mm
 Camber angle 1.5 °
 Upper arm spacer 0 mm
 Toe angle 0 °
 Rebound stop 1 mm
 Bump stop None Use
 Upper arm position 1 mm
 Anti-roll bar T0138-B T0164
 Upright T0138-B T0164
 Upper arm position 1 mm

Front shock

Piston Stock
 Oil #Stock
 Spring Lt Blue
 Sock position

Front Diff.

One way
 Gear diff. Oil # _____
 Solid

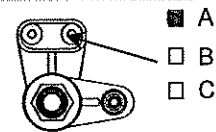
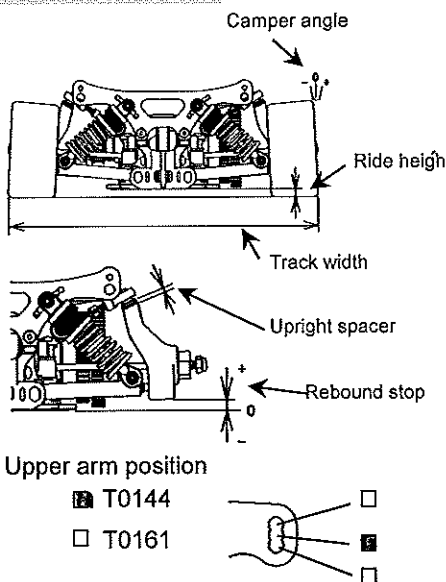
Steering ackerman

Rear suspension

Track width 200 mm
 Ride height 8 mm
 Camber angle -4R -3.5L
 Toe angle 4 °
 Rebound stop 4 mm
 Bump stop None Use
 Lower arm position
 Upright spacer 2 mm
 Anti-roll bar Wire ϕ 2.3
 Adjustable(T0162)
 Upright position T0144 T0161
 Wheel Hub Spacer 1 mm

Rear Shock

Piston Stock
 Oil #450
 Spring Lt. Blue
 Shock position

Rear Diff.

Oil #30,000

Engine

Type Murnan 353
 Gasket _____ mm Muffler Sky line VR12+
 Plug _____ Fuel _____

Tire

<Front> Type 42 Kawahara <Rear> Type 42 Kawahara
 Dia.(start) L62/R 62 Dia.(start) L64/R 64
 Dia.(finish) L57/R 57 Dia.(finish) L56/R 57

Clutch

Clutch shoe Black Gray Yellow
 Centrifugal shoe H0766
 Spring MSR
 Clutch bell clearance .4 mm
 Spring adj. Nut position .97 mm

Brake pad

Black Other

Body

Type Protoform 3.1
 Wing Stock

Drive ratio

Gear ratio Side pulley
 1st. 17/59 24T
 2nd. 23/53 25T

Result

Race time / Lap 3rd A. main
 Best lap (1Lap) _____

Comments:

Started with purple rear springs and 10,000 rear diff. The track came around to Lt. blue and 30,000 in the rear. The car had good balance and lots of steering