

# **SERPENT** 835

1:10 SCALE 235mm GAS ON-ROAD COMPETITION

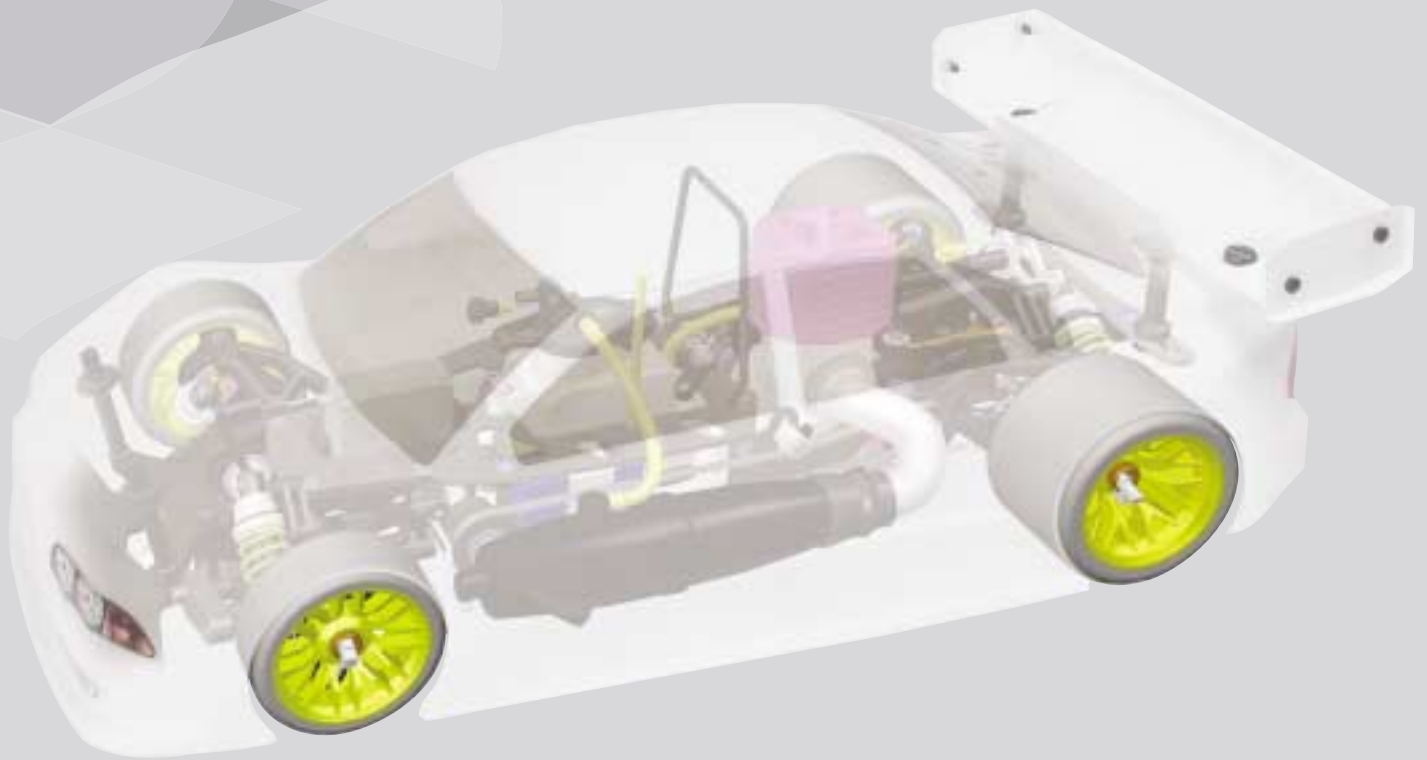

## *Instruction Manual*

**CompetitionX**  
A WEB SITE FOR THE SERIOUS RACER

# SERPENT 835

## Introduction

### Overview

Congratulations with your newly acquired Serpent 835. You have chosen for the highest quality and ultimate performance combined with ease of use in assembling and set-up as well as superior technical support.

Serpent has a tradition with instruction manuals, and with the new Serpent 835 manual we have yet again gone a step further. The new lay-out has easy to follow step-by-step assembly instructions and building tips, richly illustrated with 3-D rendered images and printed in full color. Following the steps in the manual will result in a well built high performance racing car that will soon be able to unleash its full potential on the racing track.

### Instructions

This manual has 10 sections that will lead you through the assembly process of each of the sections of your Serpent 835. Following this order will ensure that no problems occur during assembly.

Each of the steps includes an area where all the screws, fasteners and ball bearings are shown which are used in that particular step. When it is necessary to open a bag for a step of the assembly it will be shown at the top of the left box. When a bag number is specific to a 2wd or to a 4wd version it will state it in brackets and your kit, depending on the version, will only include that specific bag.

### Set-up

In certain assembly steps you need to make basic adjustments. These basic adjustments will give you a good rough set-up for your Serpent 835 once the car is completed. Fine-tuning the basic set-up is necessary however, this is an essential part of the process of building a high performance mode racing car like the Serpent 835.

The Set-up Guidelines in section 10 of this manual help you to adjust your Serpent 835. It is very important to follow this procedure and to be accurate with your adjustments, not only now, but every time you are preparing the car to go practicing or racing. This is how the best drivers in the world do it, simple, straight forward and accurate!

### Exploded views and parts list

The parts list and the exploded views for the Serpent 835 are separate from the Instruction manual. The exploded views show all the parts for a particular assembly step, together with the Serpent part number. In the parts list at the back of the Reference Guide you will find, with the part number, the name of the part for easy reference when re-ordering.

### Safety precautions

We have enclosed a document with safety precautions concerning the assembly and use of this product, named 'Read this first'. In your own interest, read this document and follow the precautions.











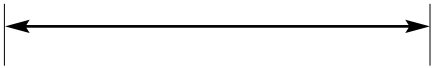

## Contents

	<i>Description</i>	<i>Page</i>
1.0	Shock Assembly	4
2.0	Front Assembly	7
3.0	Differential Assembly	10
4.0	Rear Assembly	12
5.0	Radio Plate Assembly	16
6.0	Radio Plate Mounting	18
7.0	Gearbox Assembly	20
8.0	Centax Assembly	22
9.0	Final Assembly	25
10.0	Setup Guidelines	29

PERFORMANCE THROUGH EVOLUTION

# How to use

In every step you will see a selection of lines and numbers. The numbers represent the order in which the step should be assembled. The lines and symbols are listed below each with their own explanation as to their use.

Key	Description
	Length measured after assembling between the two black lines.
	To display the path of one element into another.
	The parts within the lines should be assembled first.
	The direction the item should be moved.
	Shows where one element should be glued to another.
	Shows where one part should be pressed / inserted into another.
	Displays where two elements should be connected to each other.
	The gap between two elements.
   	Displays where either CA glue / Graphite Grease / Thread Lock / or Serpent's Oneway lube should be applied (items not included).

## myTSN.com

The manual that comes with your Serpent 835 is very complete. However, as development is a continuous process, up-to-date information about the Serpent 835 is provided on our web portal: myTSN.com, the state-of-the-art r/c technology portal where Serpent racers from all over the world meet and exchange their ideas and share useful information about, and experiences with, their Serpent cars.

All information about the Serpent 835 is grouped around the product page on myTSN.com. This page can be accessed directly by going to the Products section and type Serpent 835 in the product search box.

Here you will find the very latest information about your Serpent 835: reports by Team racers and other experts with the latest tips and tricks, FAQ,

forums, set-ups, image gallery, downloadable files, and even streaming video about the Serpent 835 on how to further improve the car. The latest version of the manual including team and racer tips, as well as part lists and option lists will be made available as both downloadable PDF-files and viewable online under **i-Manual** in the Serpent 835 product page.

So make sure to visit myTSN and the Serpent 835 page. There is a world of up-to-date information about your 835 waiting for you, and it is just a few mouse clicks away... If not yet a member of myTSN, we strongly suggest to sign up as a member immediately so you can experience and enjoy an even wider range of services from Serpent and other myTSN partners.

[www.myTSN.com/Serpent835](http://www.myTSN.com/Serpent835)

# 1.0 Shock Assembly

**Step 1.1**      *Bag 01*

835 Shock Assembly

- **N3**  
3x6x0.3mm
- ☪ **R2**  
2.3mm
- ☪ **R1**  
1.9mm

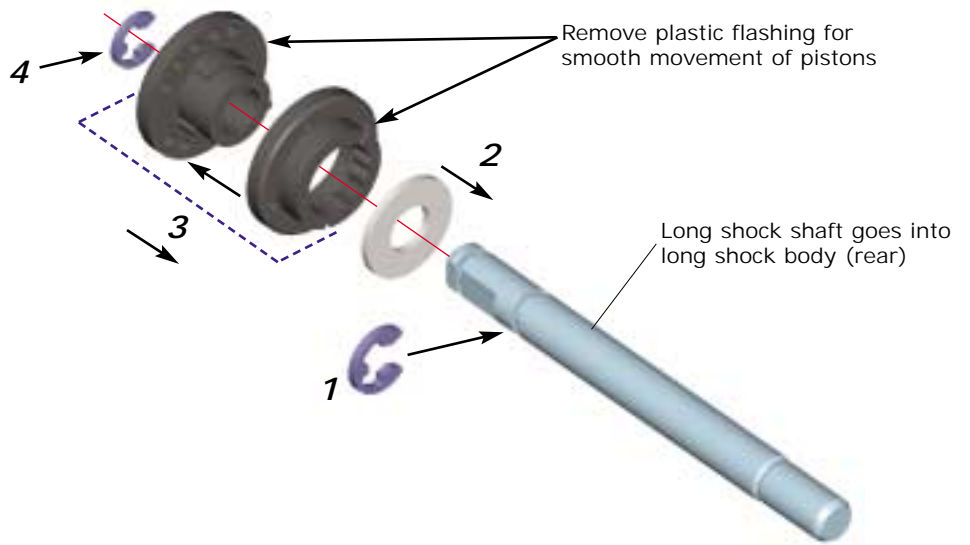

**Step 1.2**

835 Shock Assembly

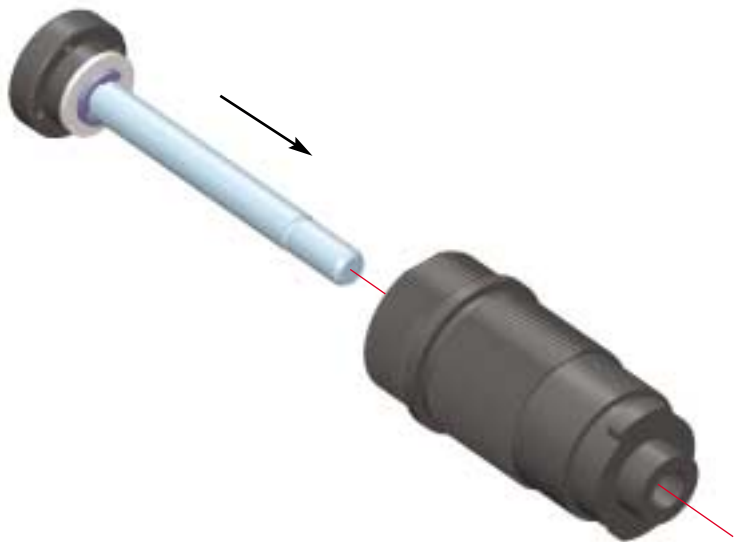

**Step 1.3**

835 Shock Assembly

- **Y17**  
12.1x1.6mm

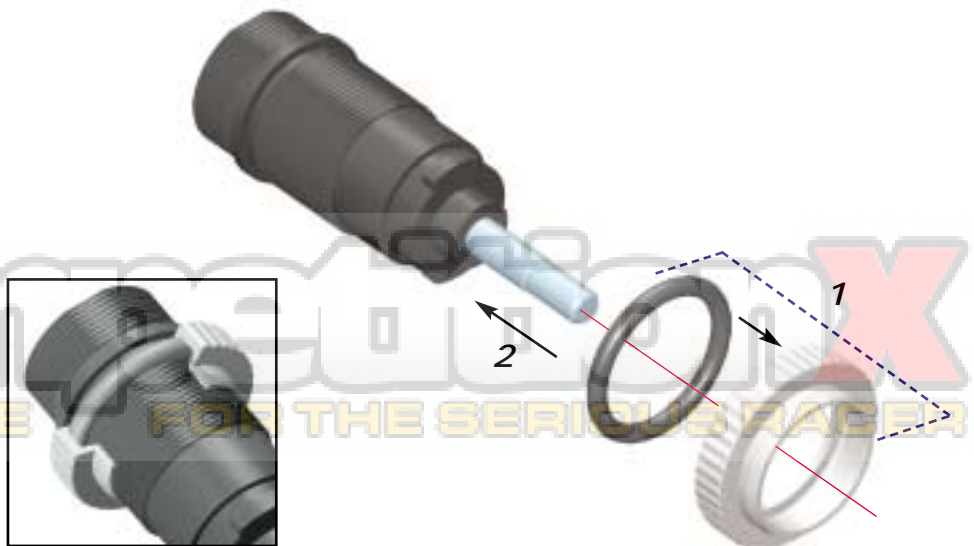

## Step 1.4

835 Shock Assembly



Y4  
3.1x1.6mm

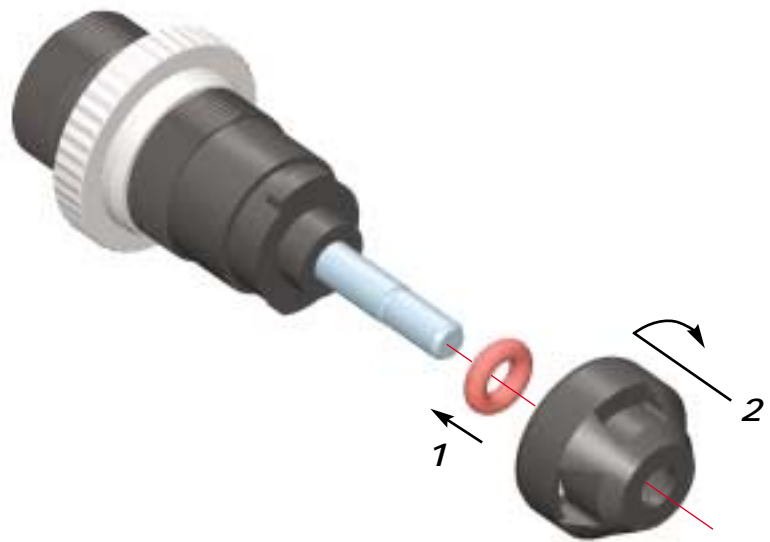

## Step 1.5

835 Shock Assembly

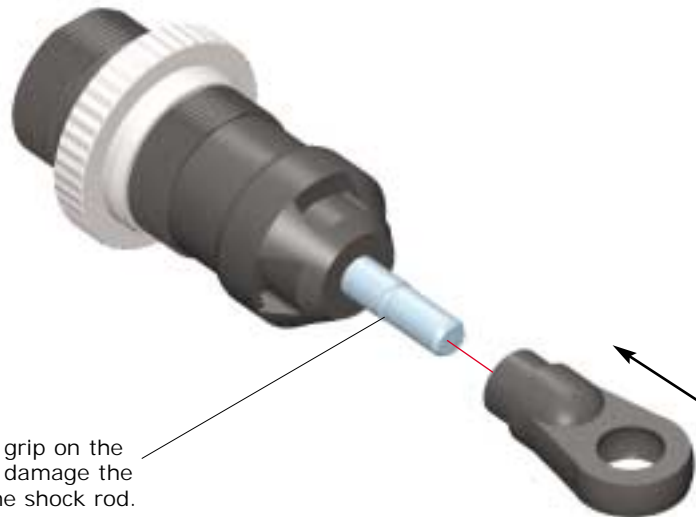

Hold the shock rod firm using pliers, grip on the part where the thread begins, do not damage the shock rod. Turn the ball-joint on to the shock rod.

## Step 1.6

835 Shock Assembly

Fill the cylinder with shock oil, with the piston in the bottom position.

Bleeding sequence: Let the oil settle and allow the air to escape. Slowly move the piston up and down until no more bubbles appear.



**CompetitionX**  
A WEB SITE FOR THE SERIOUS RACER

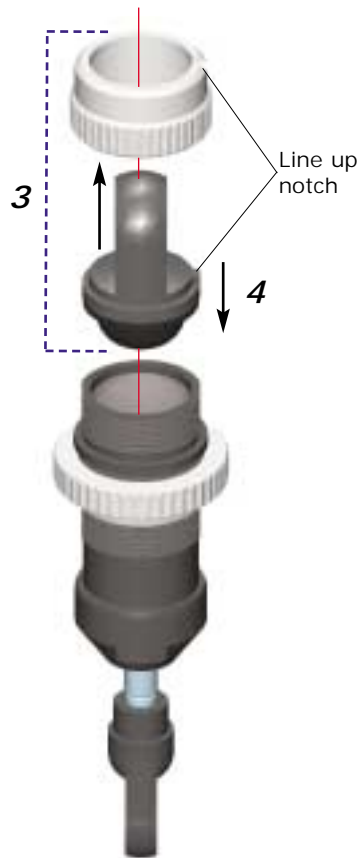
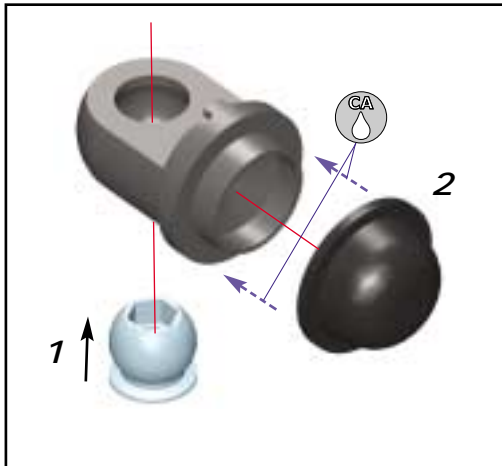

**Shock length adjustment**

Check the length of the shocks, adjust with the ball-joint.

Shock Front: 67,5mm  
Shock Rear: 76,5mm

In full extended, locked position.

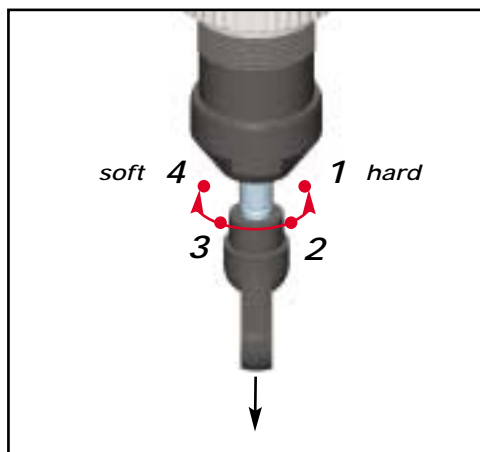

**Dampening adjustment**

Pull the piston rod all the way down, turn slightly to lock the position of the cylinder.

You can then adjust the shocks by rotating the shaft in clockwise and counter clockwise clicks from position 1-4.

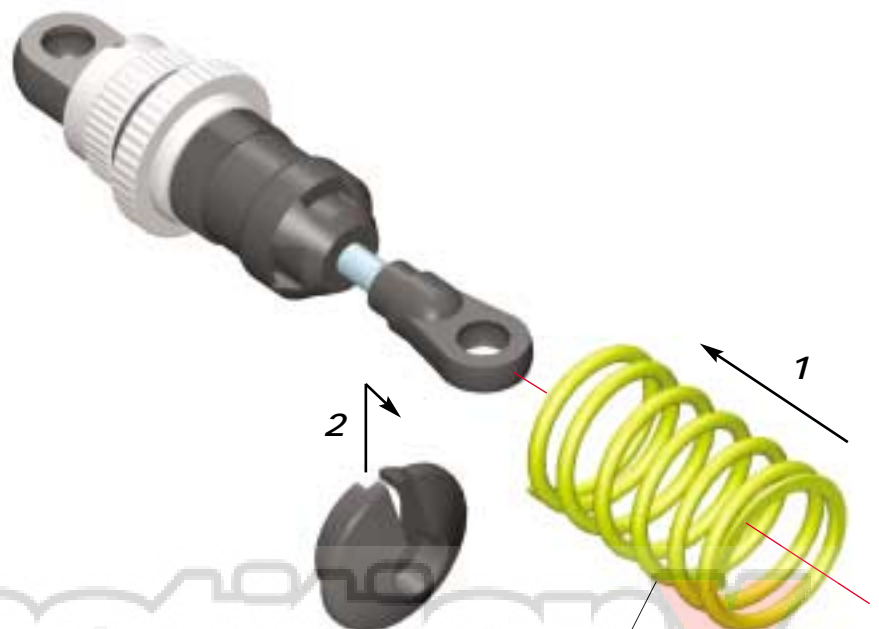

Short Springs (on short shock)- Front  
Long Springs (on long shock)- Rear

# 2.0 Front Assembly

## Step 2.1

Bag 2 (4wd)

835 Front Assembly



**Y12**  
10.3x1.8mm



**U13**  
12x18mm

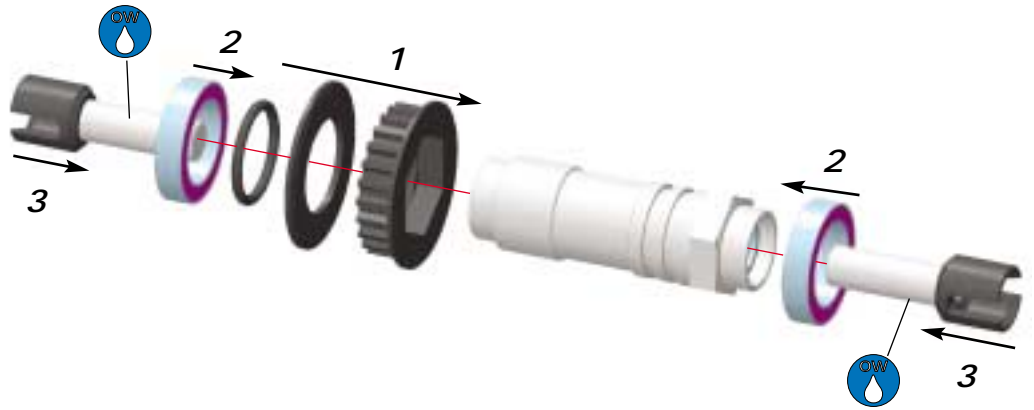

## Step 2.2

Bag B13,  
3 (2wd), 4 (4wd)

835 Front Assembly



**B13**  
3.5x13mm

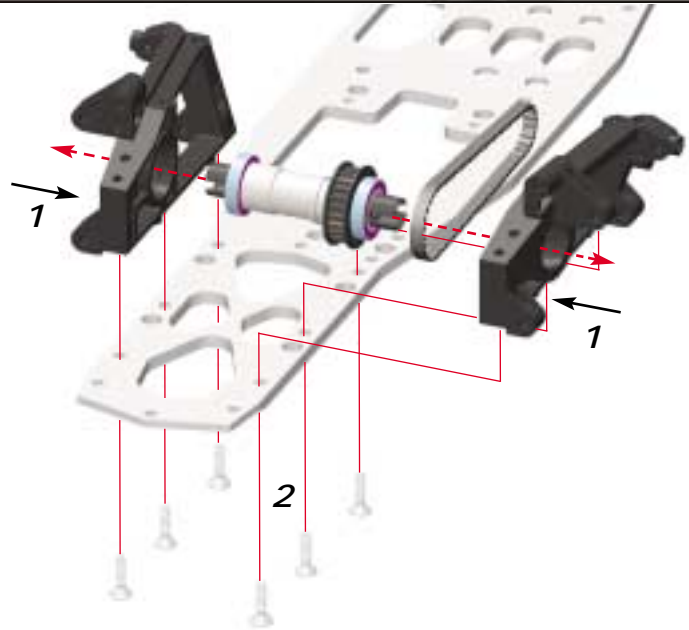

## Step 2.3

835 Front Assembly



**B13**  
3.5x13mm



**U6**  
6x13mm

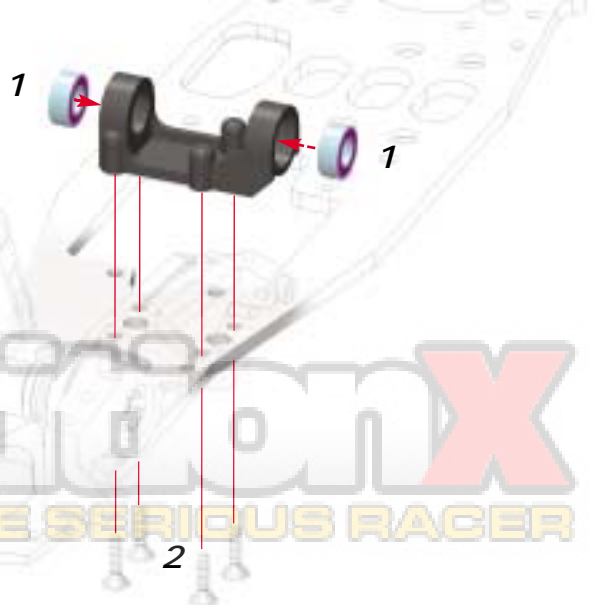

**CompetitionX**  
A WEB SITE FOR THE SERIOUS RACER

### Step 2.4

Bag 5 (4wd)

Front Assembly



J16  
4x4mm



R5  
5mm



R7  
7mm

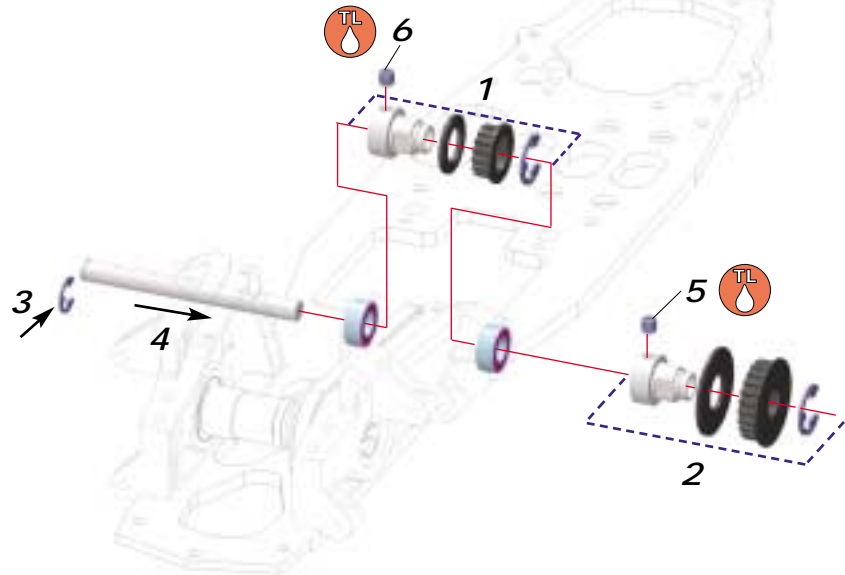

### Step 2.5

Bag 06

Front Assembly



H13  
3x12mm



H19  
4x10mm



J16  
4x4mm

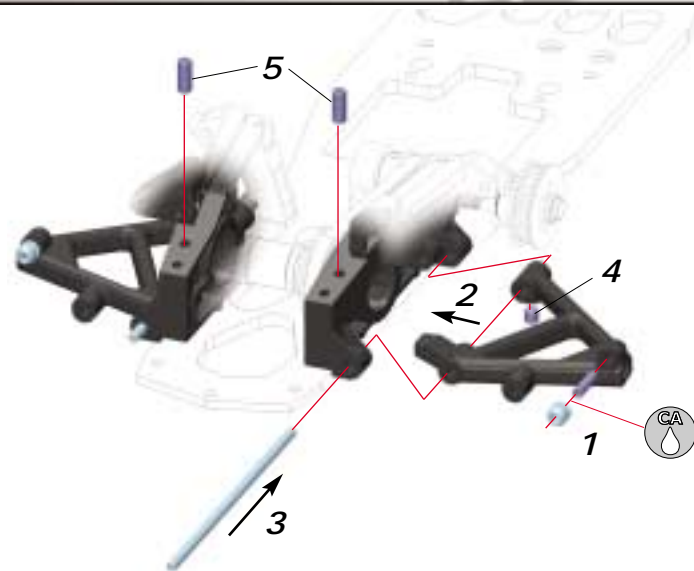

### Step 2.6

Bag 07

Front Assembly



J17  
4x6mm



E13  
3x12mm

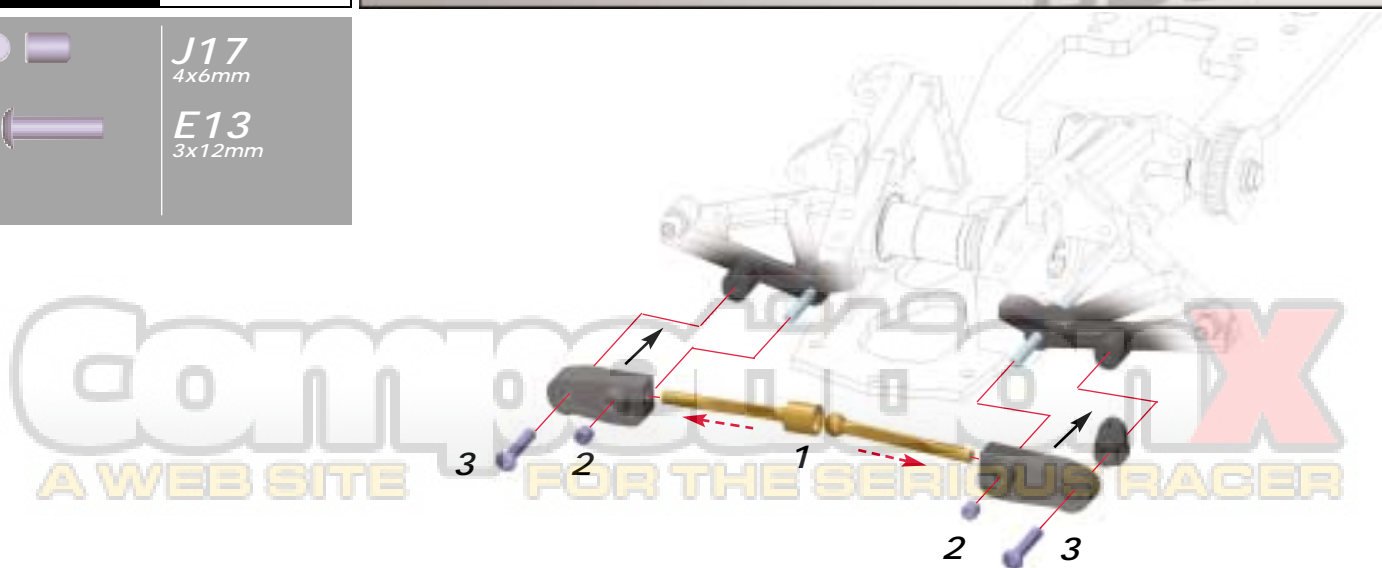



### Step 2.7

Bag 08

Front Assembly



J16  
4x4mm

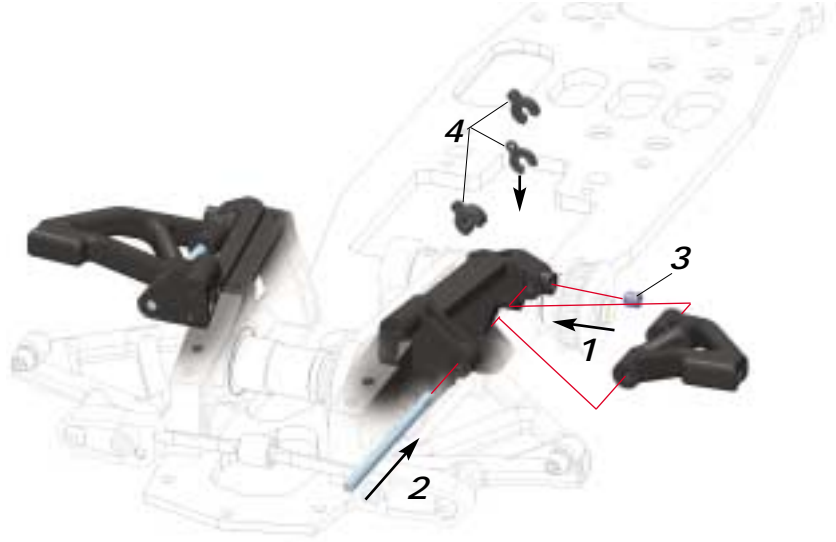
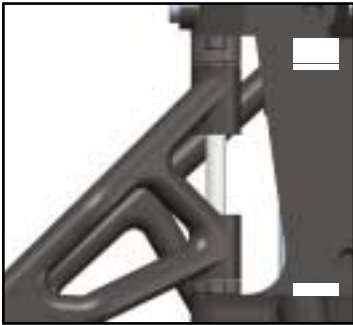

### Step 2.8

Bag 9,10 (2wd),  
11 (4wd)

Front Assembly

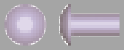

E10  
3x6mm



P7  
2.5x16mm



U12  
10x19mm

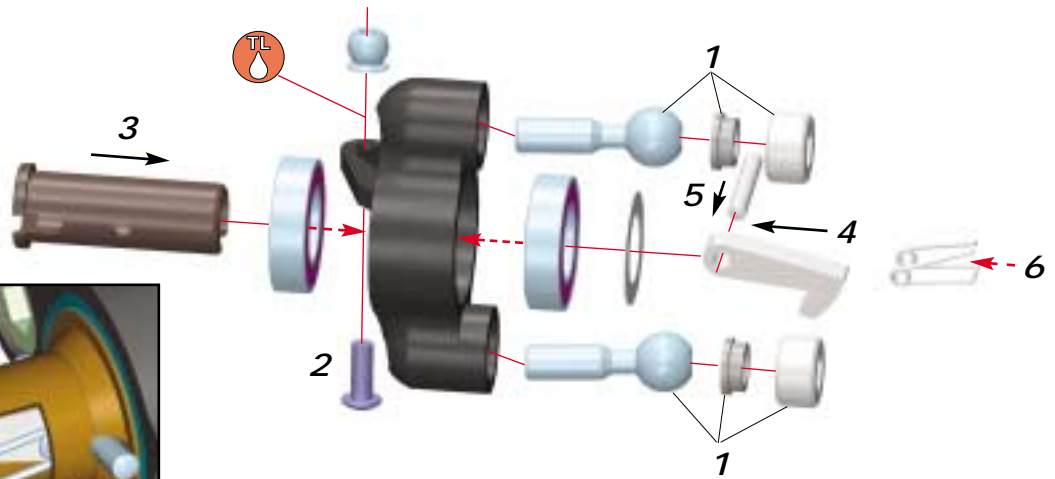

### Step 2.9

Front Assembly

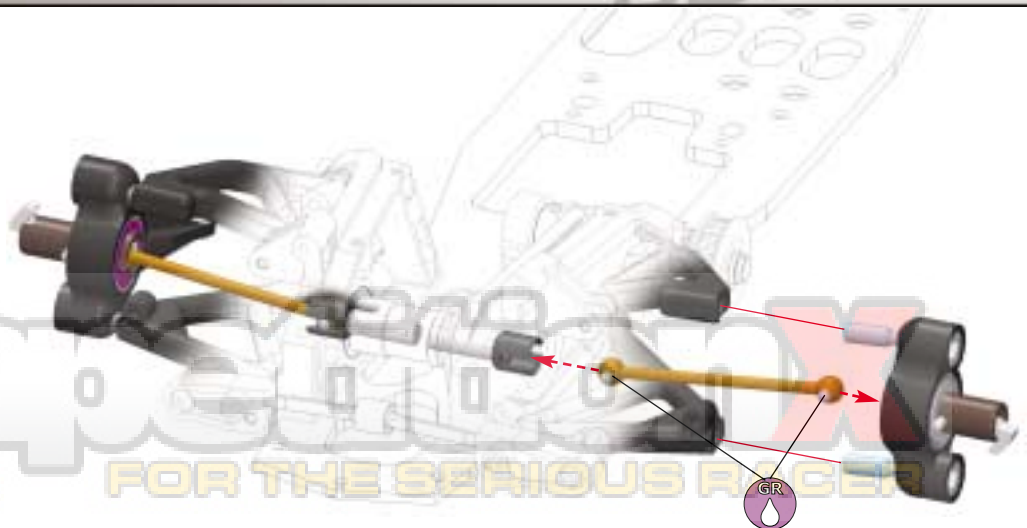
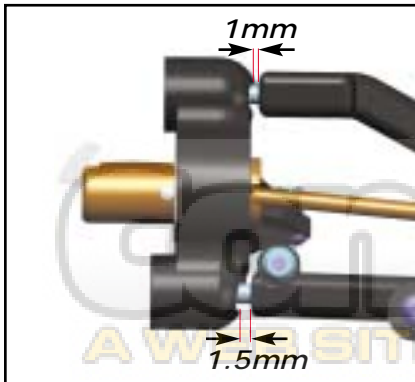

# 3.0 Differential Assembly (2wd)

## Step 3.1

Bag 12 (2wd)

Differential Assembly

Press in all three pins until flush with rear of the pulley.

Smaller inner diameter of the 2 thrust washers.

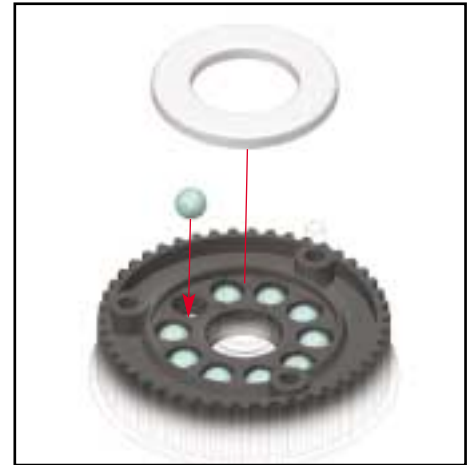
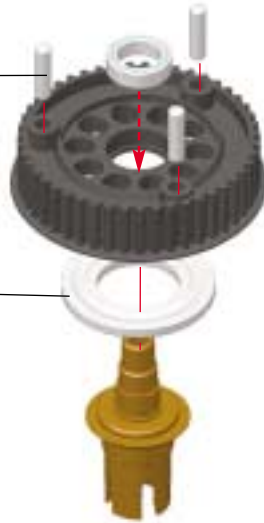

## Step 3.2

Bag 13 (2wd)

Differential Assembly

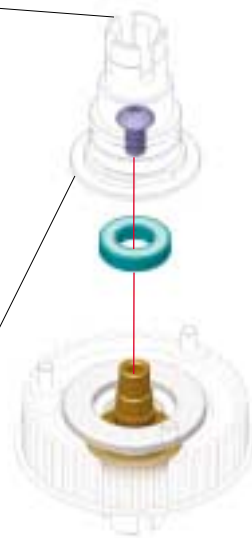
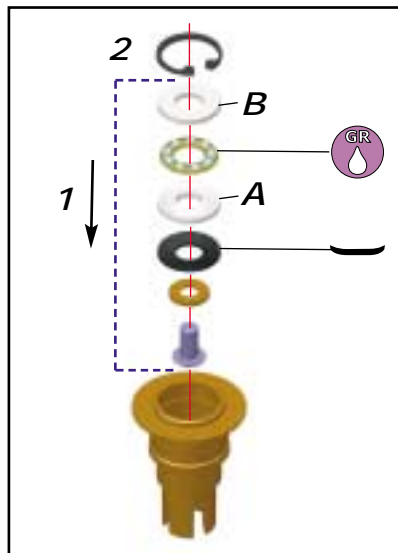
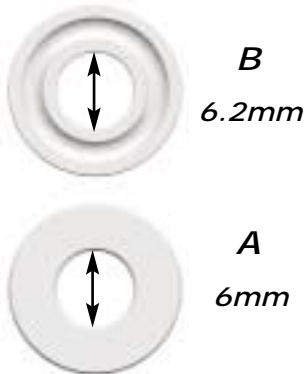

Use this screw to apply pre-load to the differential. Tighten it so that the diff pulley doesn't slip while holding both diff shafts but still turns as freely as possible.

## Step 3.3

Differential Assembly

### Initial Setting

1. Check the pre-load. Hold both diff shafts by placing long pins or screwdrivers in the diff shaft slots. Try to turn the diff pulley while holding both diff shafts. The diff pulley should not slip until significant force is applied. This force is the maximum force that you feel when opening the throttle while holding the rear wheels. This adjustment is a matter of developing some 'feel'. When the pulley slips too easily, apply more pre-load. If the diff does not slip even when applying a lot of force, reduce some pre-load and test again.
2. When a satisfactory pre-load setting is found, apply the locking grub screw from the other side, and tighten it against the pre-load setting screw to lock it in place.
3. When the car is finished, the pre-load setting of the diff should be checked by holding the wheels while opening the throttle. The diff pulley should not slip at all. If it does, the differential pre-load needs to be increased. To do this the rear suspension needs to be disassembled until the 2 drive shafts can be removed. Undo the locking grub screw, then tighten the diff pre-load screw and tighten the locking grub screw again. Assemble the rear suspension and check the differential pre-load setting again.

Tighten this locking grub screw to lock your initial setting.



Roughen the metal discs with sandpaper before gluing

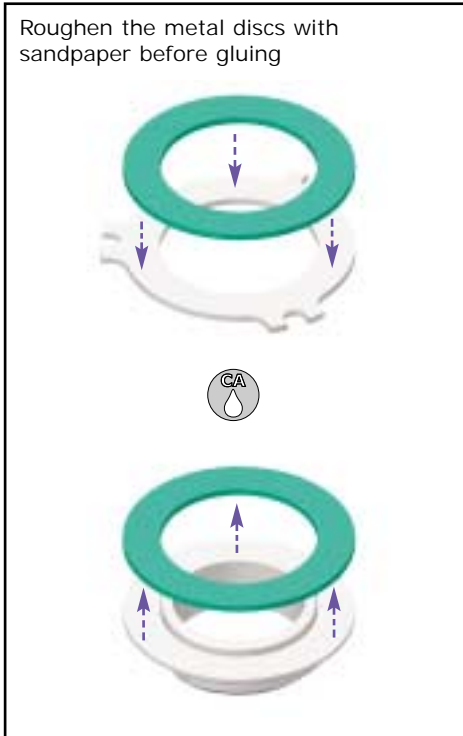

Tighten this locking grub screw to lock your differential setting

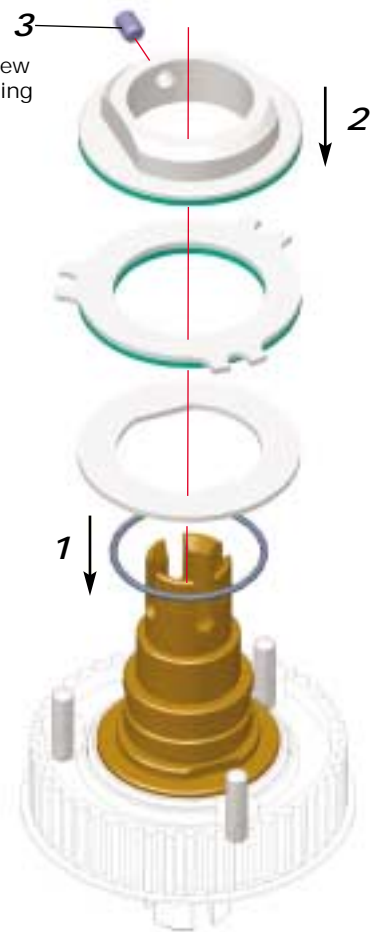

**Adjusting the Differential**

1. Loosen the locking grub screw.
2. Adjust the friction plates. Loosen the set-screw and tighten the alu. nut. This will increase the load on the friction plates and will increase the spin-resistance of the differential. The tighter the plates are together, the more the differential will resist the difference in speed between the inner and the outer wheel. As a rule of thumb, the more grip on a track, the more load should be applied to the friction plates.
3. Lock your setting by tightening the locking grub screw

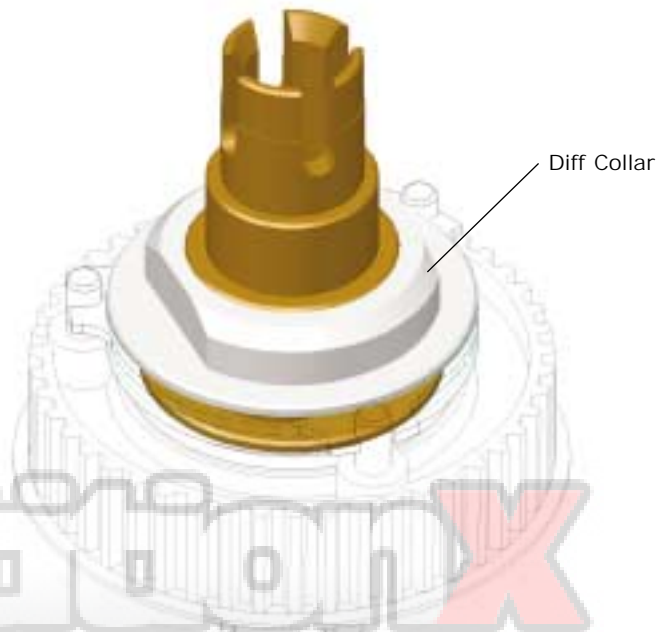

**COMpetitionX**  
A WEB SITE FOR THE SERIOUS RACER

# 4.0 Rear Assembly

## Step 4.1

Bag 15,  
16 (4wd)



**B13**  
3.5x13mm



**P8**  
2.5x18mm



**P10**  
2.5x22mm



**Q11**  
3x10mm



**R4**  
4mm



**U6**  
6x13mm



**U13**  
12x18mm

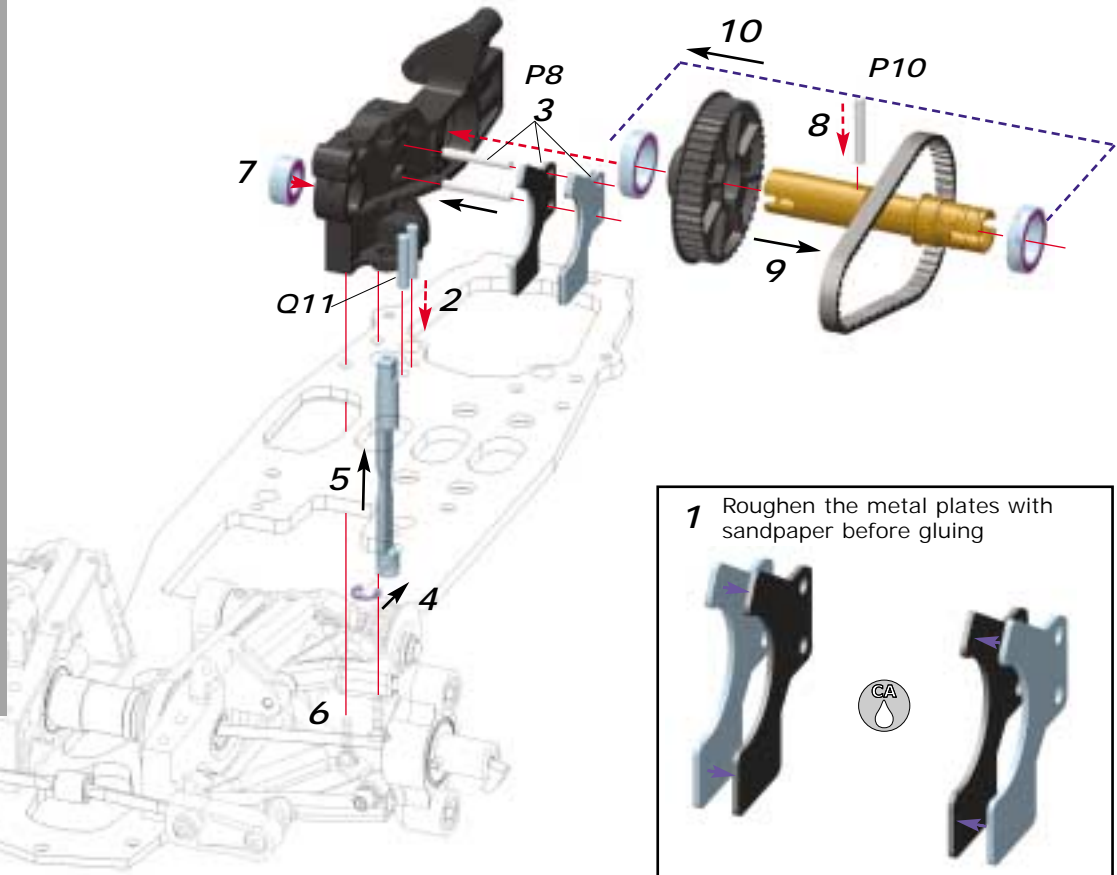

## Step 4.2

Bag 15,  
17 (2wd)



**B13**  
3.5x13mm



**P8**  
2.5x18mm



**Q11**  
3x10mm



**R4**  
4mm



**U6**  
6x13mm



**U13**  
12x18mm

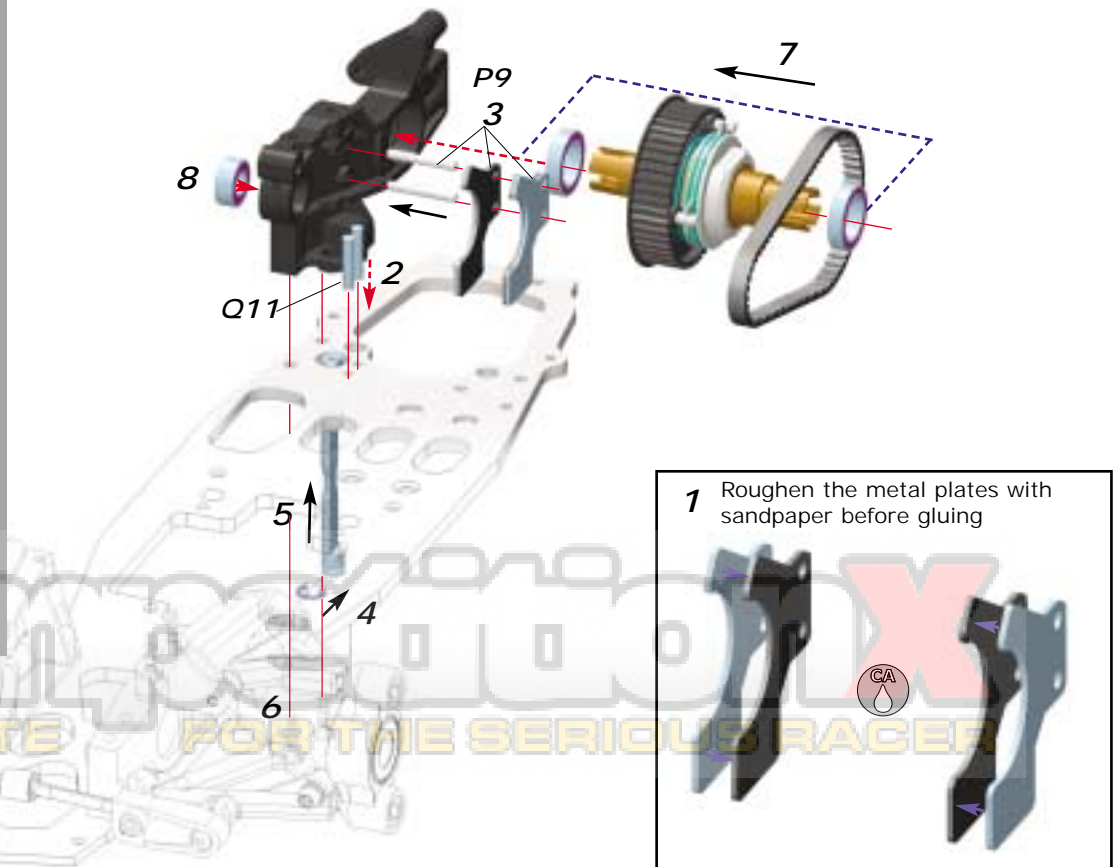

### Step 4.3

Bag 18,19

835 Rear Assembly



**B12**  
3.5x9.5mm



**B13**  
3.5x13mm



**J16**  
4x4mm

**P12**  
3x12mm



**R5**  
5mm



**U6**  
6x13mm

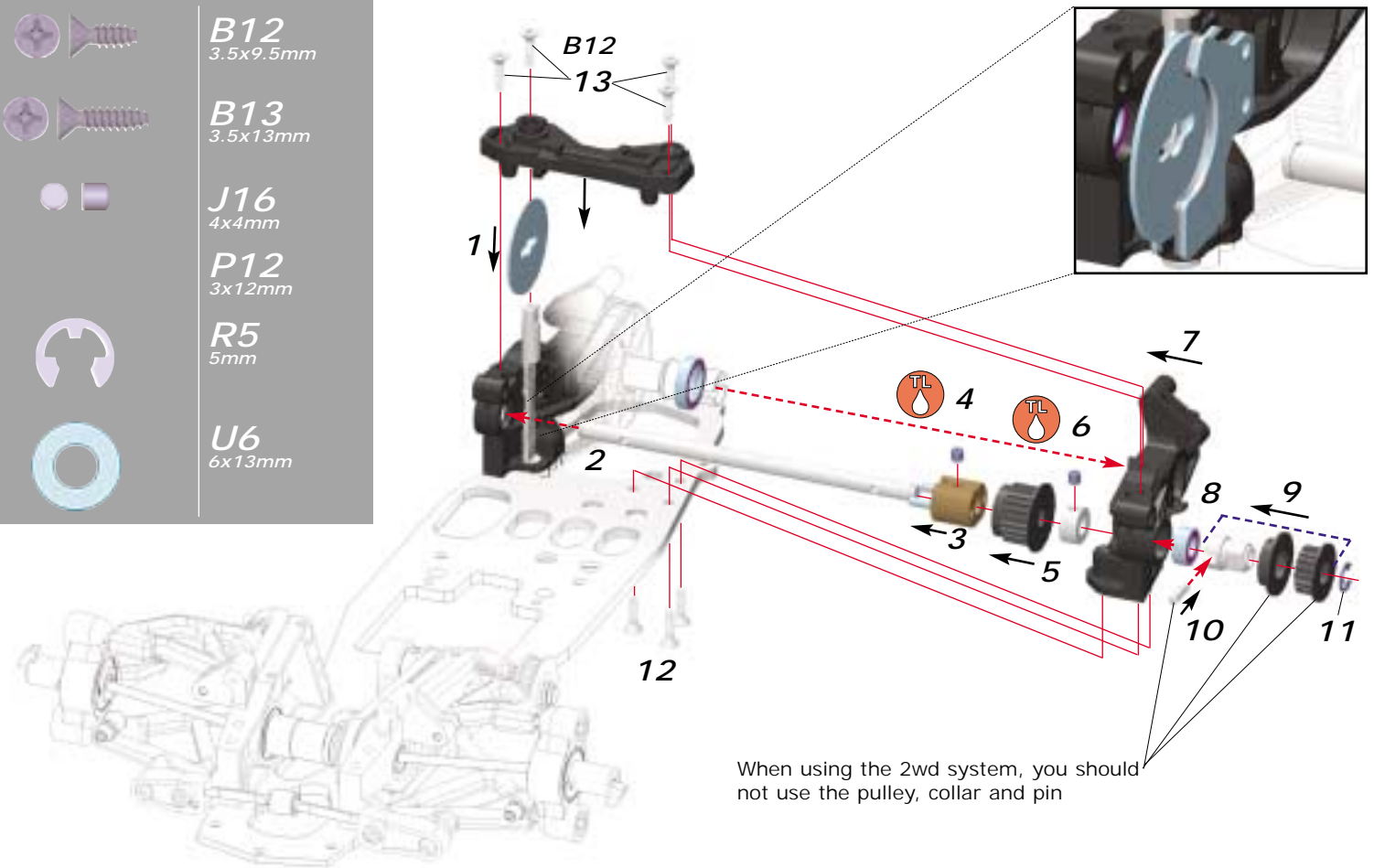

### Step 4.4

Bag 20,21

835 Rear Assembly



**A13**  
3.5x13mm



**B13**  
3.5x13mm



**E10**  
3x6mm

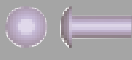

**E11**  
3x8mm



**H19**  
4x10mm



**J16**  
4x4mm

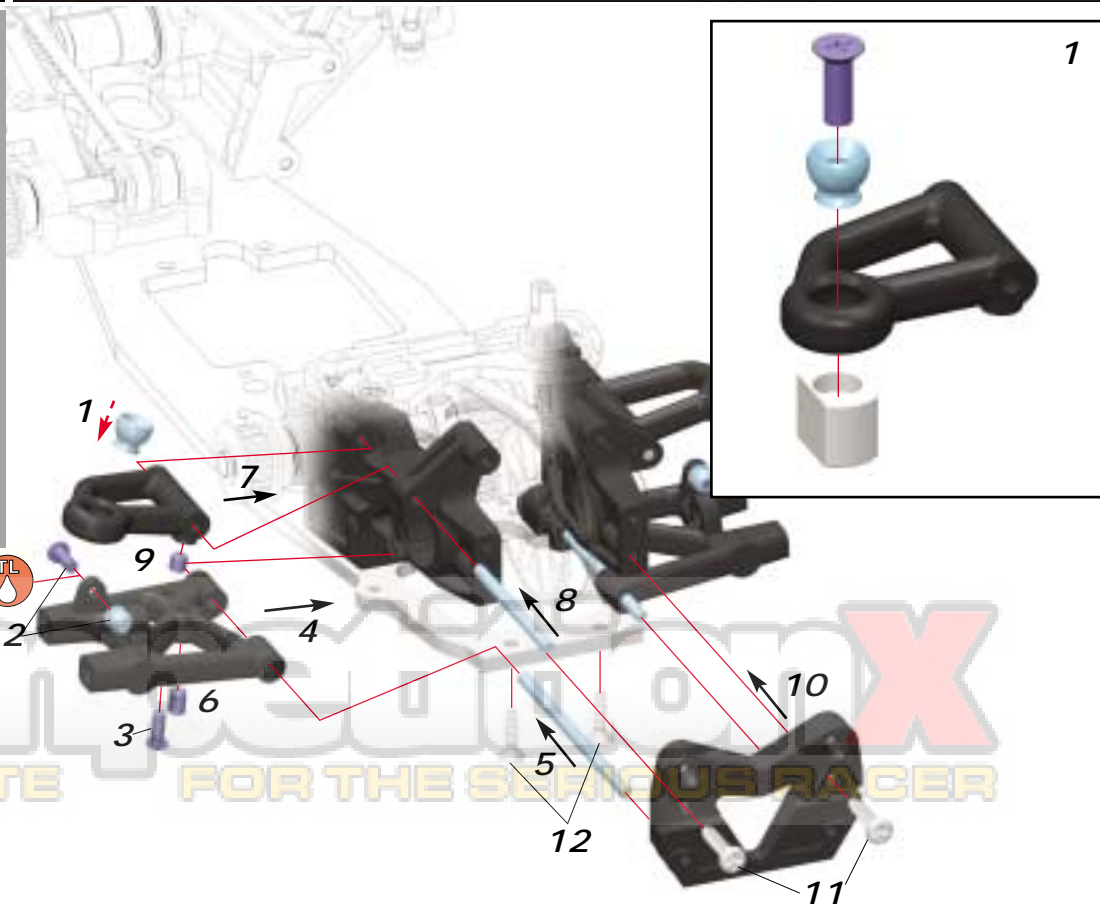

**COMET**  
A WEB SITE FOR THE SERIOUS RACER

### Step 4.5

Bag 22

Rear Assembly

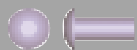

**E11**  
3x8mm



**NN4**  
3.2x9x0.1mm

**Note:** The anti-roll bar must move freely in order to operate correctly - never over tighten the mounting screws.

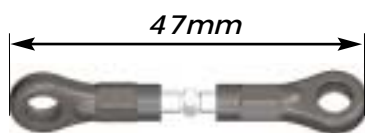

1:1

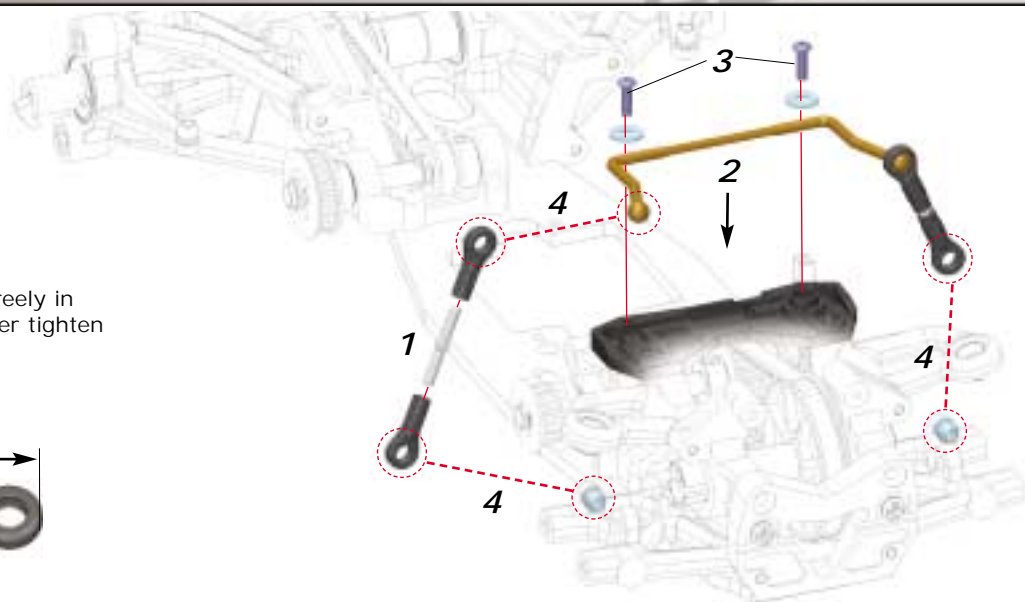

### Step 4.6

Bag 23,24

Rear Assembly



**H13**  
3x12mm



**P8**  
2.5x16mm



**U12**  
10x19mm

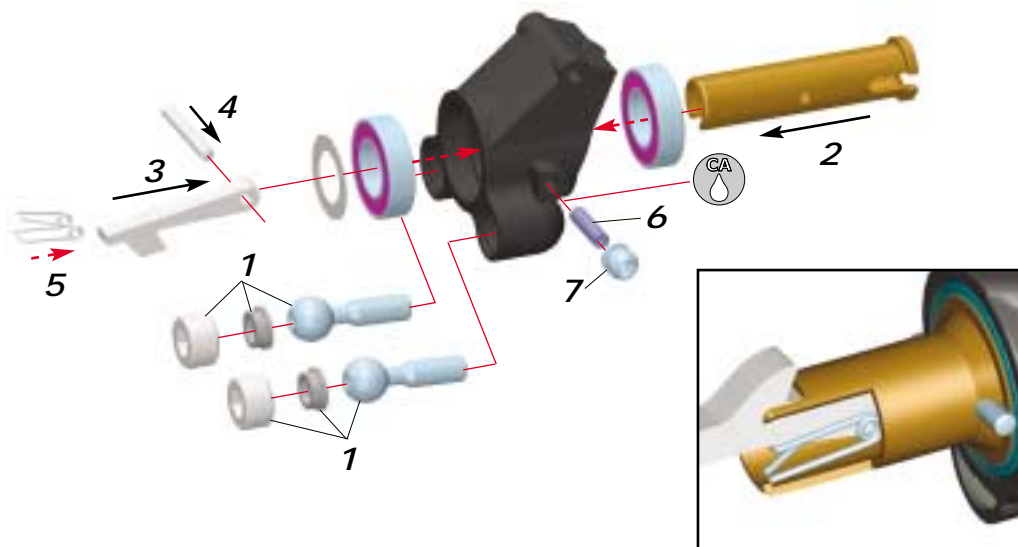

### Step 4.7

Rear Assembly



**G21**  
4x16mm

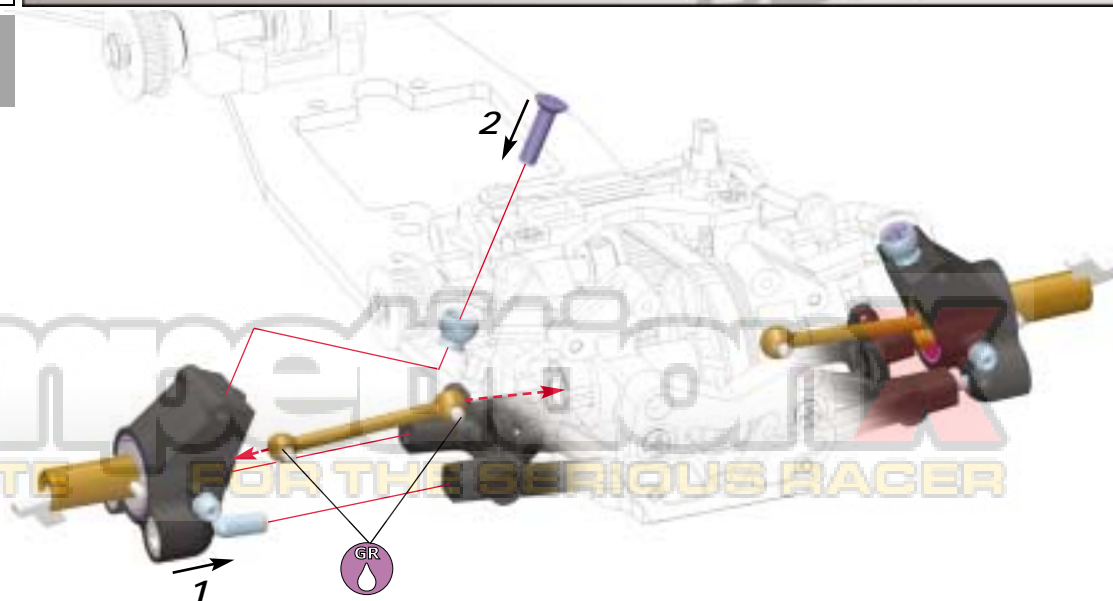
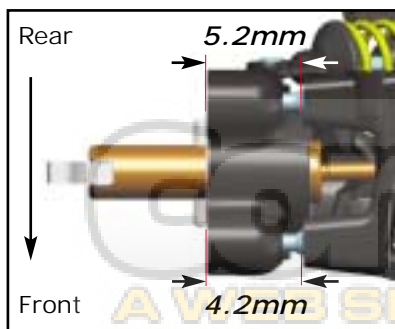

### Step 4.8

Rear Assembly



**H13**  
3x12mm

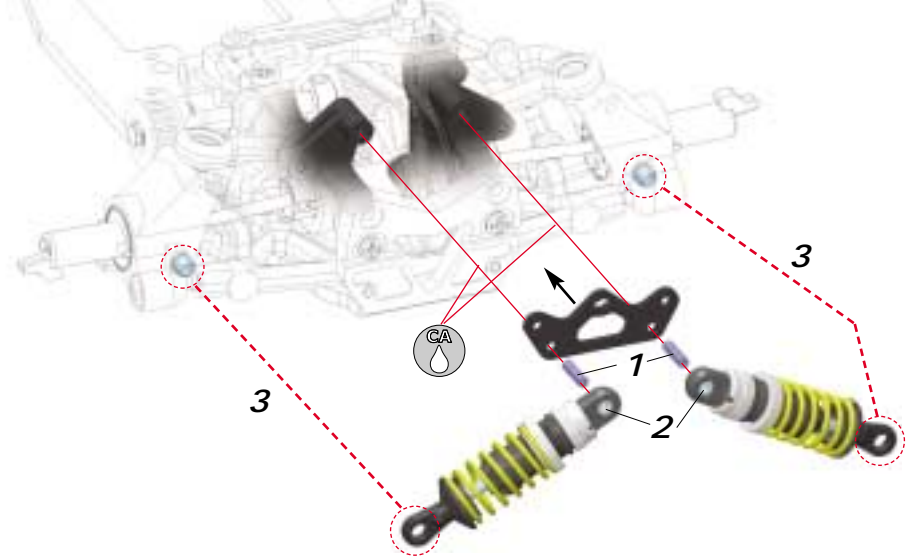

### Step 4.9A

Bag 25

Rear Assembly



**A13**  
3.5x13mm

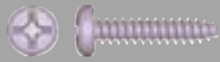

**A14**  
3.5x16mm

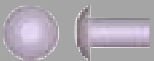

**E18**  
4x8mm



**P3**  
2x14mm

Rear Bodymount Choice #1

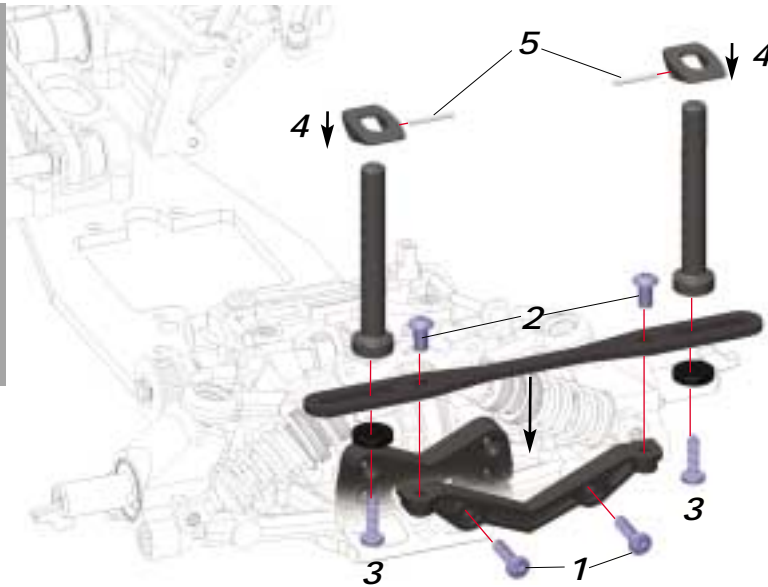

### Step 4.9B

Bag 26,27

Rear Assembly

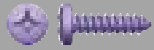

**A6**  
2.9x13mm



**B13**  
3.5x13mm

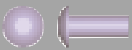

**E11**  
3x8mm



**R2**  
2.3mm

Rear Bodymount Choice #2

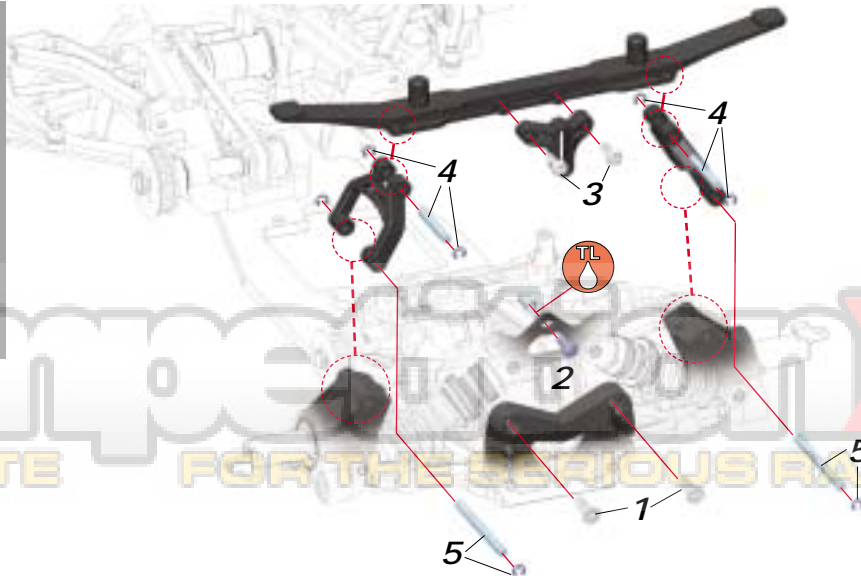





### Step 5.3



E135  
3x14mm

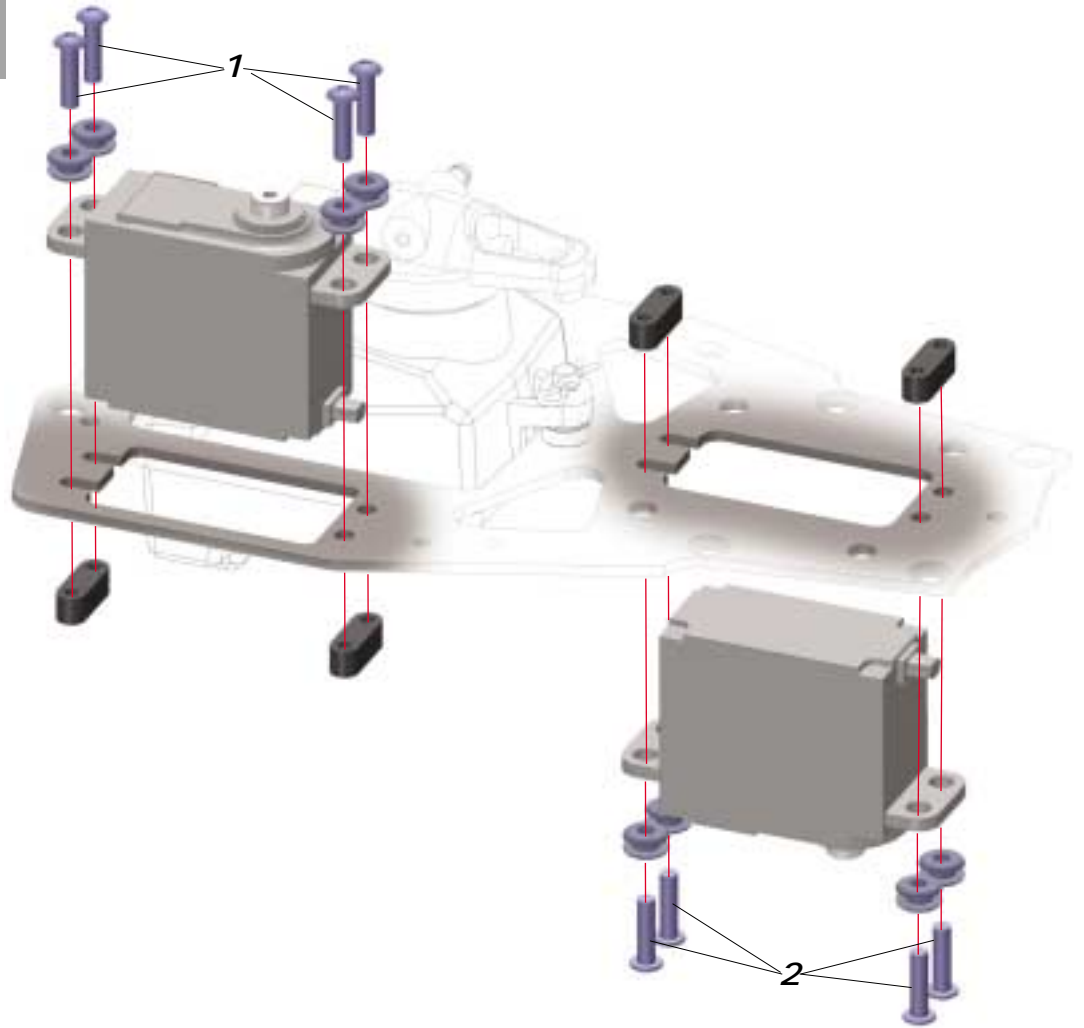

### Step 5.4

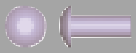

E11  
3x8mm

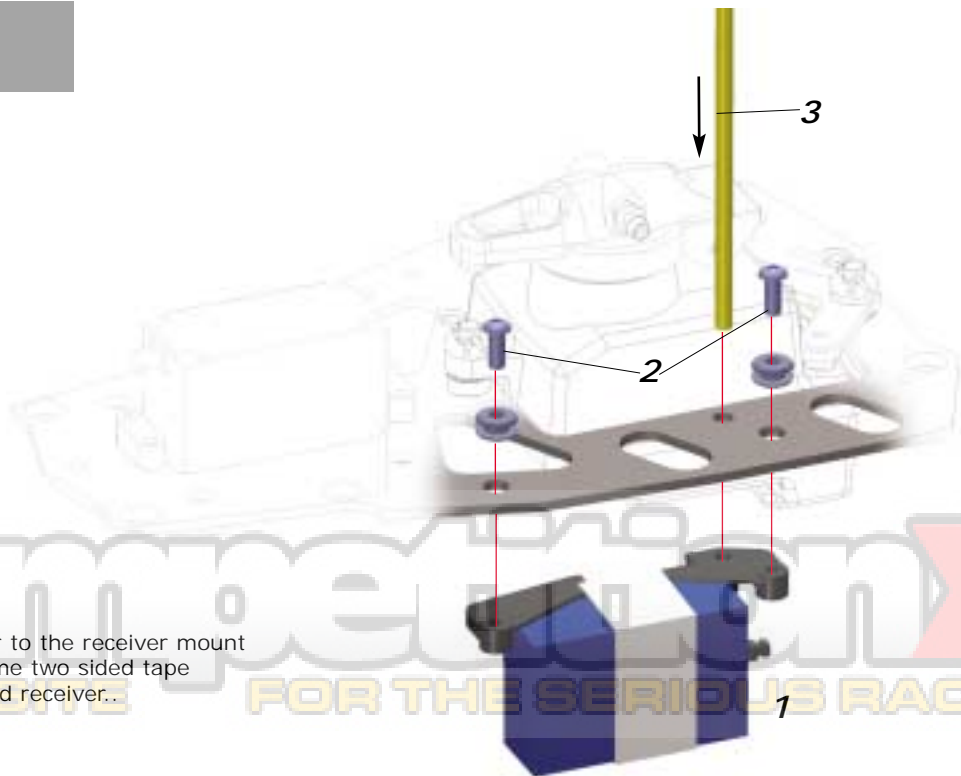

Attach the receiver to the receiver mount using tape and some two sided tape between mount and receiver...



CompetitionX  
FOR THE SERIOUS RACER

# 6.0 Radio Plate Mounting

## Step 6.1

Bag 30



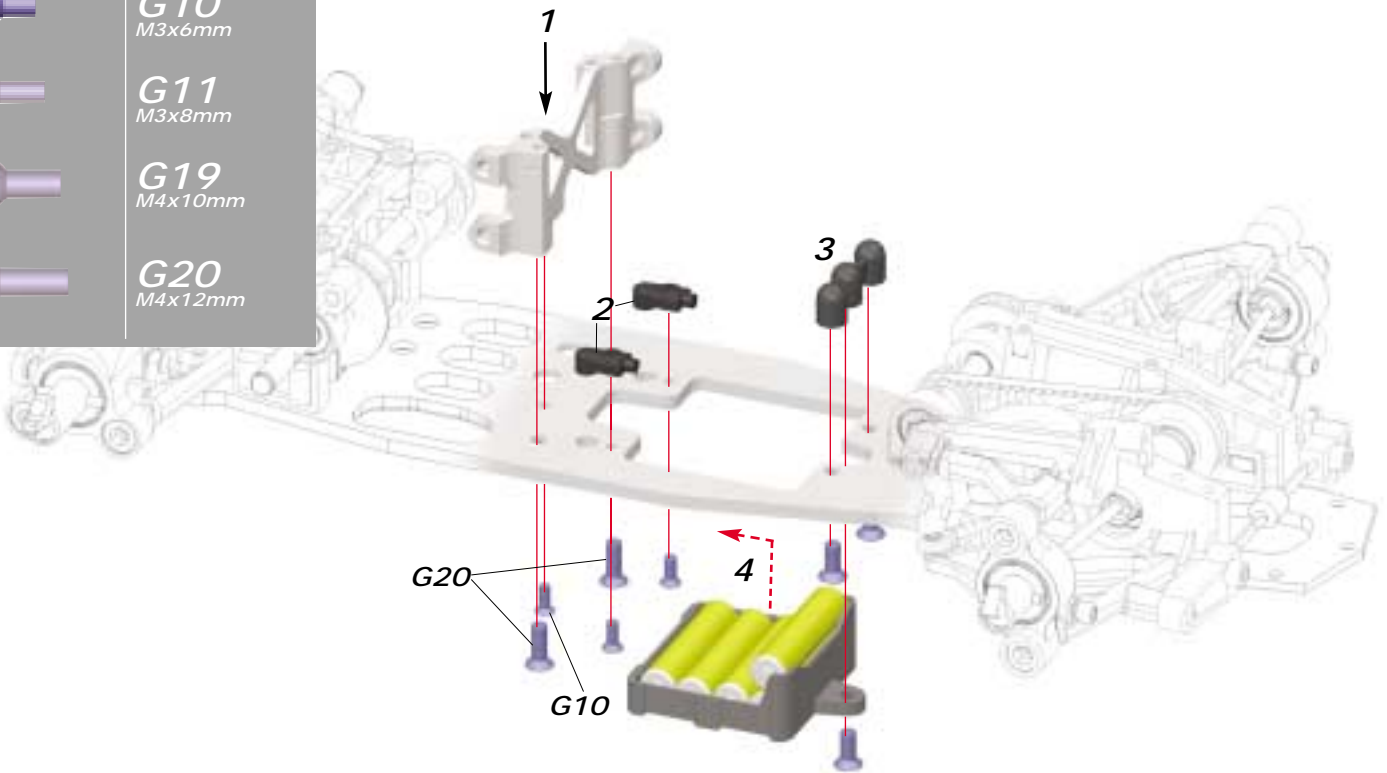

Radio Plate Mounting

-  **G10**  
M3x6mm
-  **G11**  
M3x8mm
-  **G19**  
M4x10mm
-  **G20**  
M4x12mm



## Step 6.2

Radio Plate Mounting

-  **B13**  
3.5x13mm
-  **E11**  
3x8mm
-  **G18**  
M4x8mm
-  **G20**  
M4x12mm

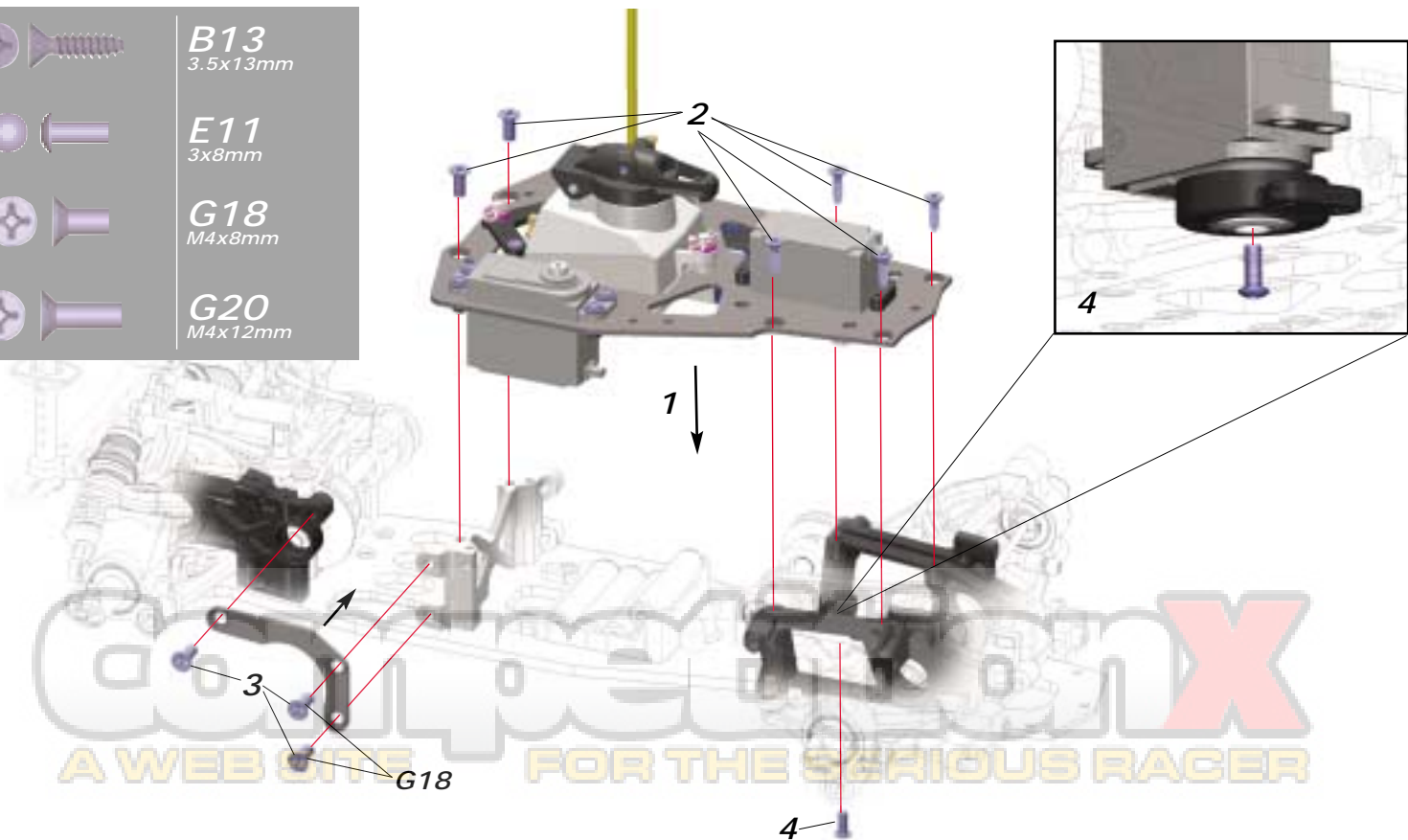

### Step 6.3

Bag 31

Radio Plate Mounting



**A13**  
3.5x13mm



**B13**  
3.5x13mm

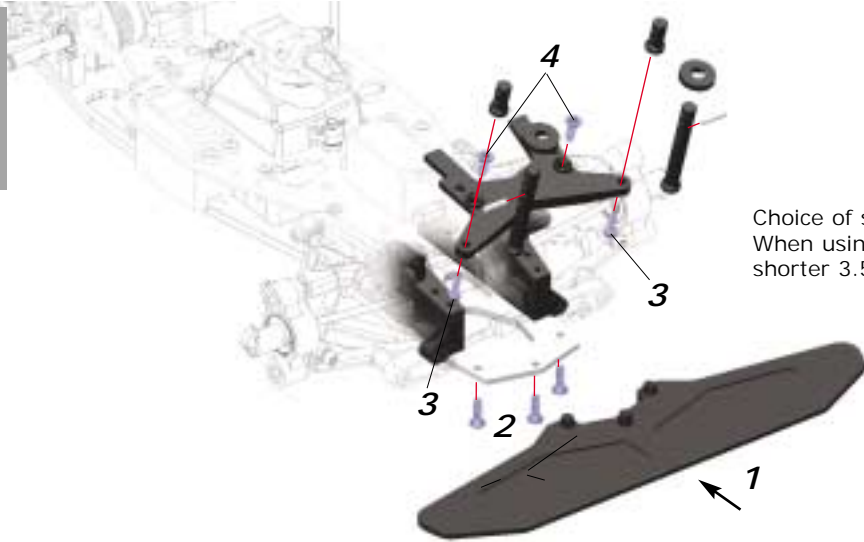

Choice of short or long body post.  
When using short post use the  
shorter 3.5x9.5mm screw (A12)

### Step 6.4

Bag 32

Radio Plate Mounting

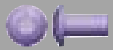

**E10**  
3x6mm



**H13**  
3x12mm

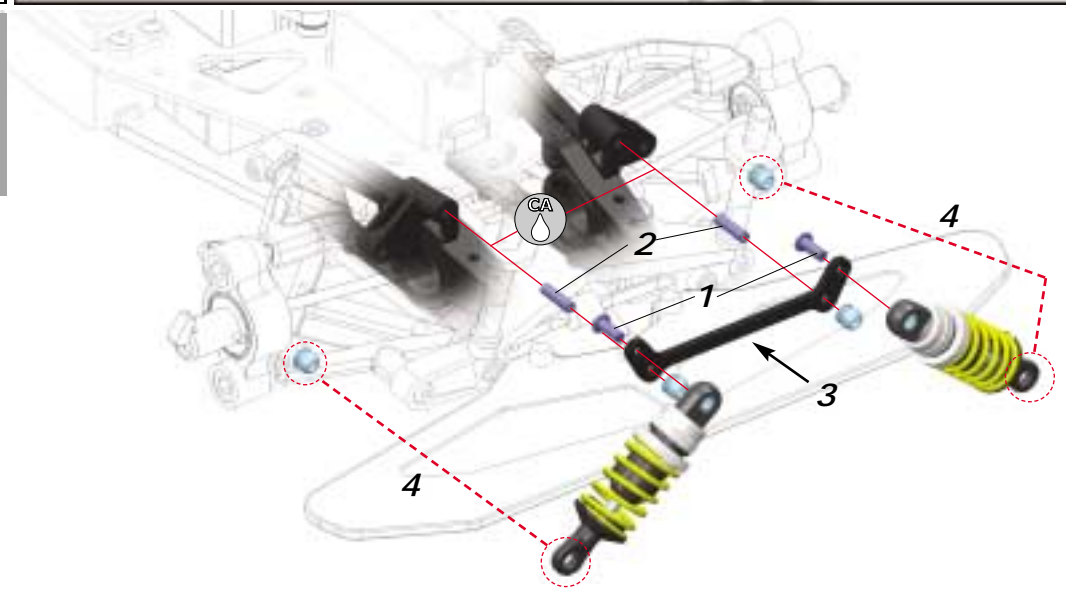

### Step 6.5

Radio Plate Mounting



**H9**  
3x4mm

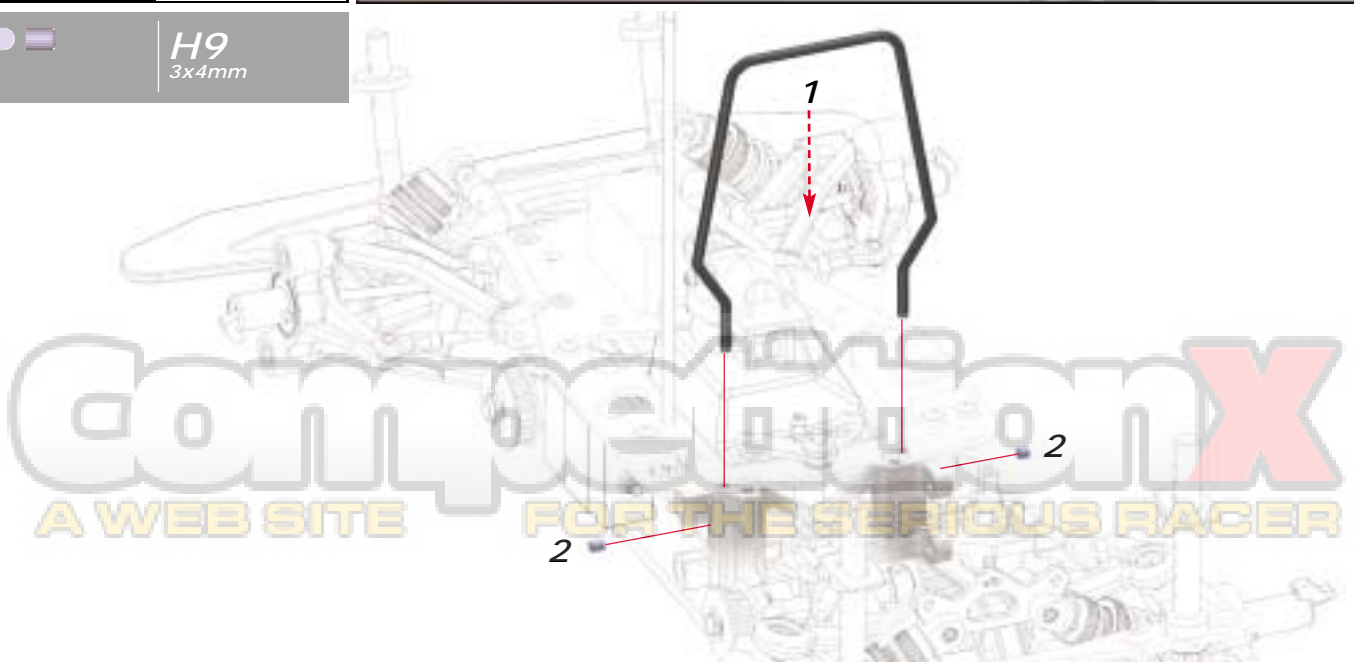

**CompetitionX**  
A WEB SITE FOR THE SERIOUS RACER

# 7.0 Gearbox Assembly

Step 7.1

Bag 33

Gearbox Assembly

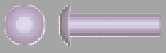

E13  
3x12mm

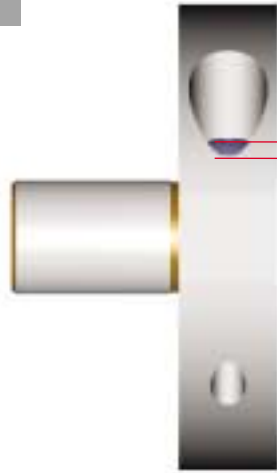

**Note:** A good starting point is to have the screw head flush with the shoe. Ensure that both sides are set equally.

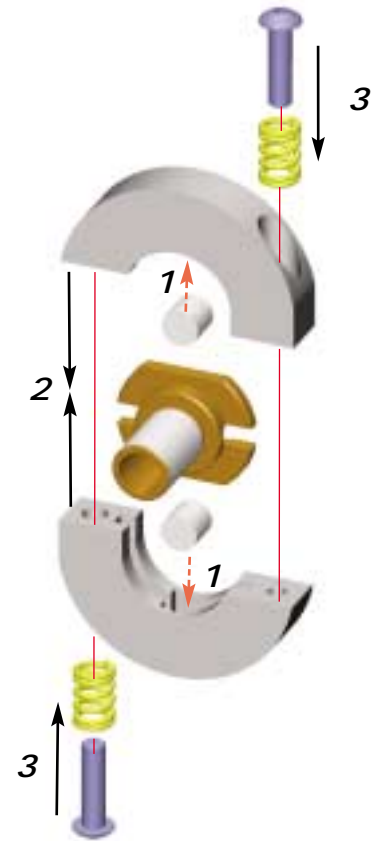

Screw IN both adjusting screws to shift LATER.



Screw OUT both adjusting screws to shift EARLIER.



Step 7.2

Bag 34

Gearbox Assembly



G10  
M3x6mm

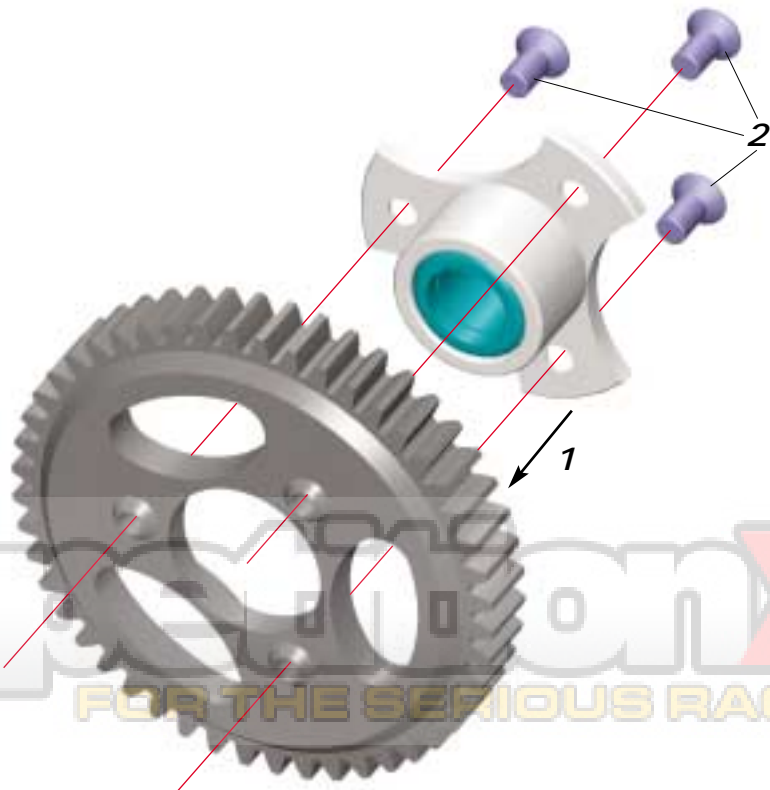

Complete on X  
A WEB SITE FOR THE SERIOUS RACER

### Step 7.3



G10  
M3x6mm



U6  
6x13mm



V5  
6x10mm

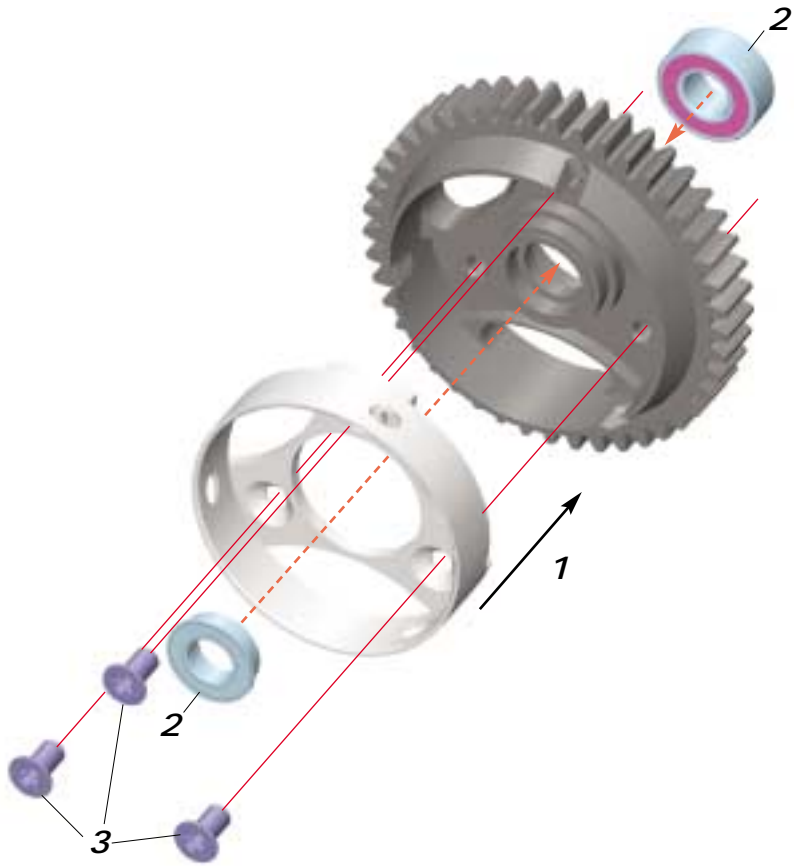

### Step 7.4



P12  
3x11.5mm



R5  
5mm

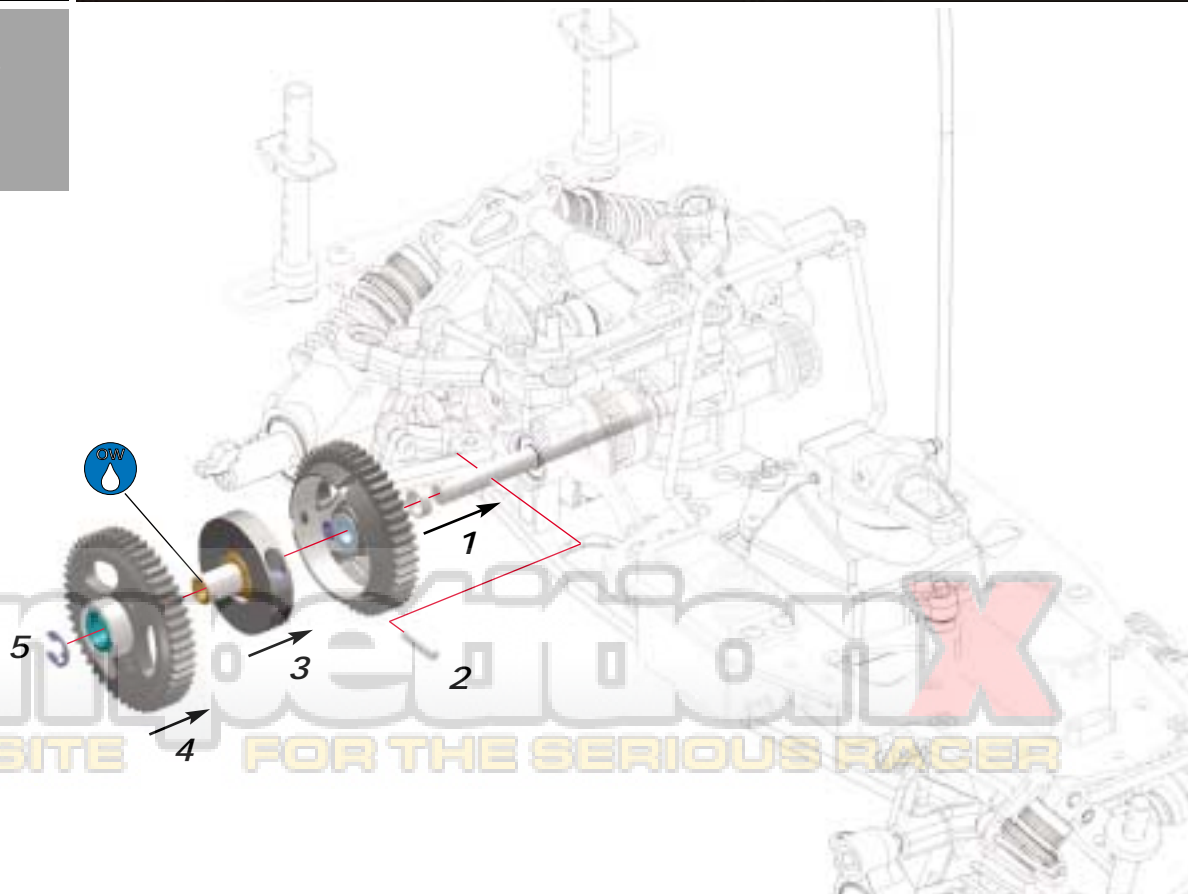

# 8.0 Centax Assembly

Step 8.1

Bag 35

Centax Assembly



M21  
7x13x0.5mm

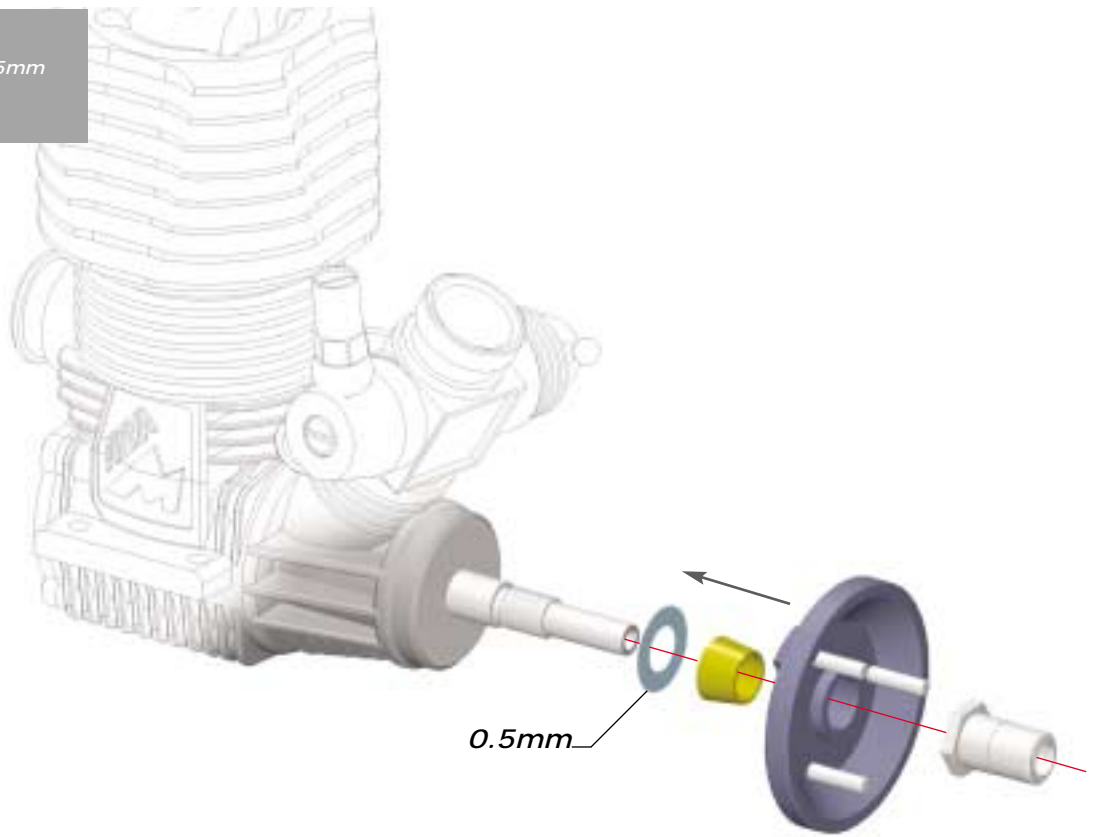

Step 8.2

Centax Assembly

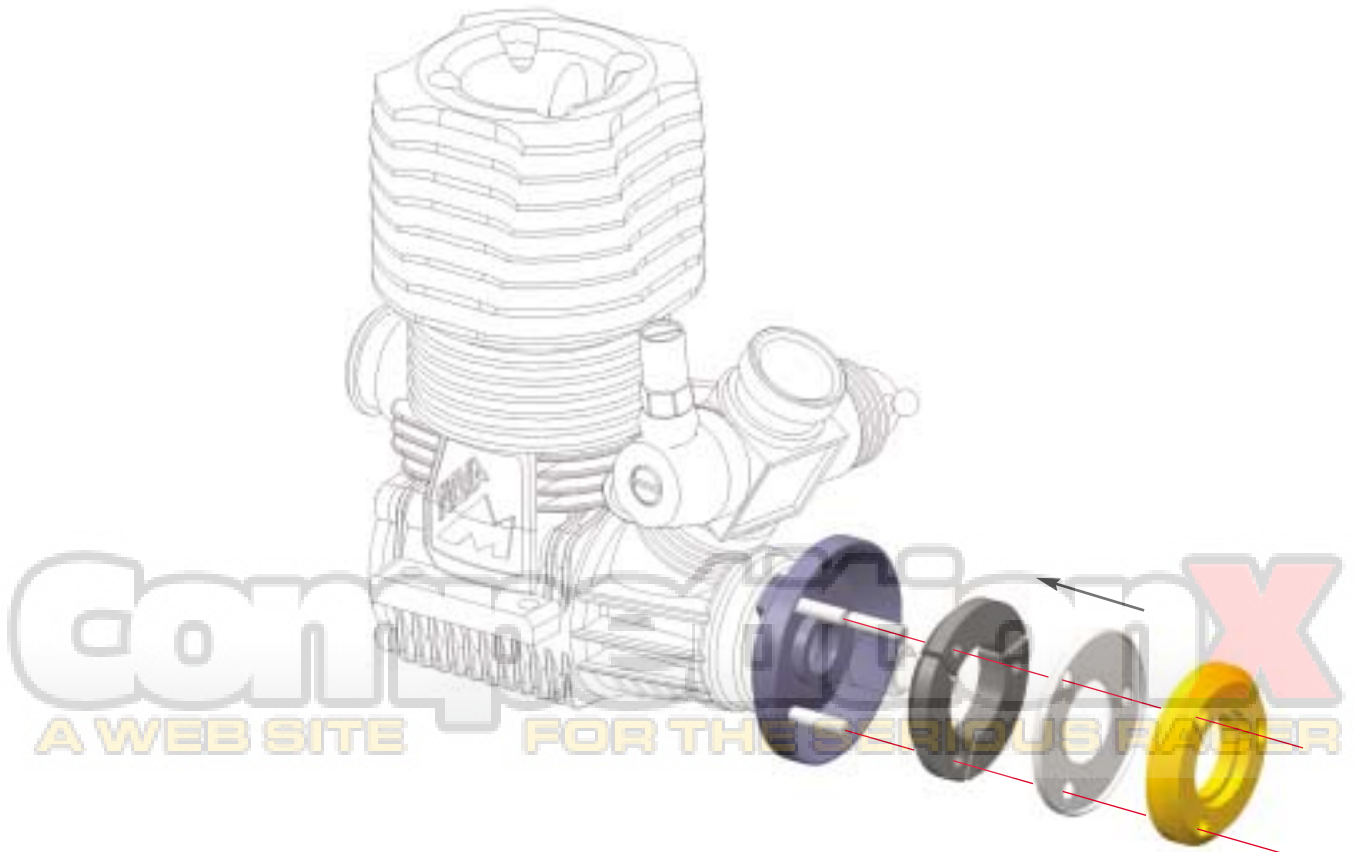

Step 8.3

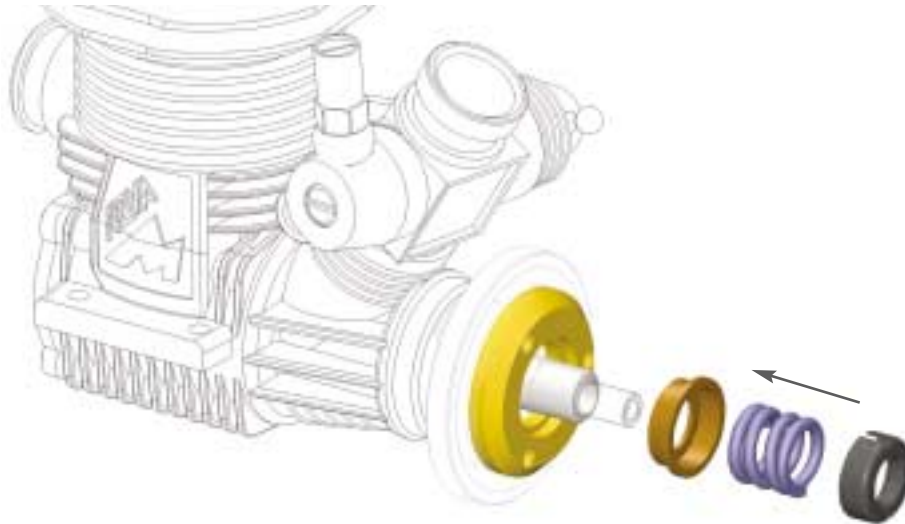

Step 8.4

Bag 36

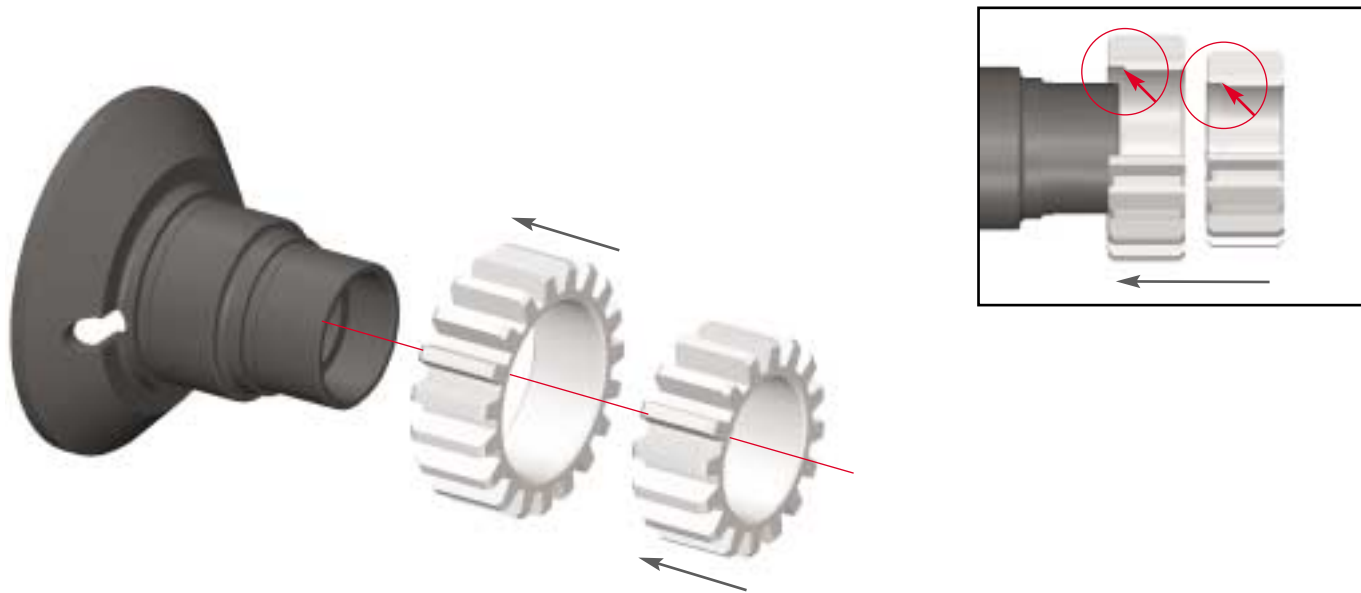

Step 8.5

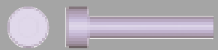

F14  
3x16mm

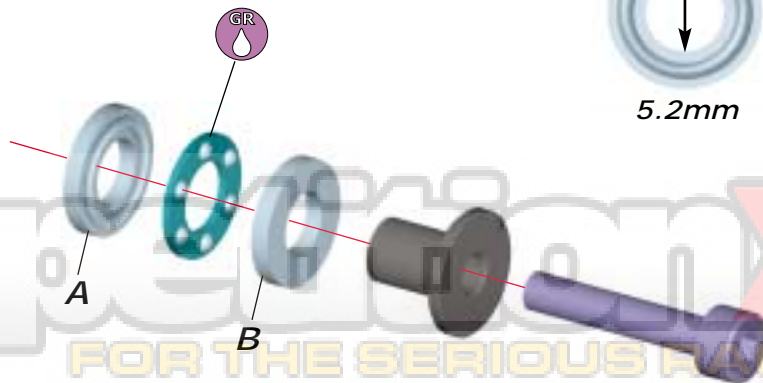
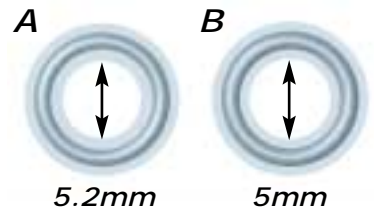

COMPETITION X  
A WEB SITE FOR THE SERIOUS RACER

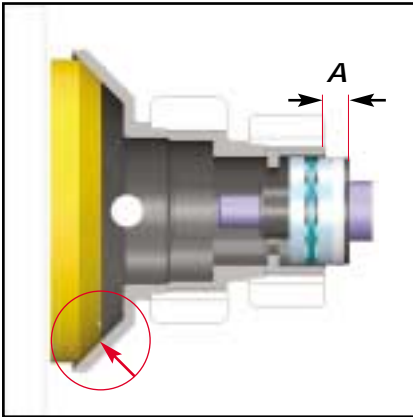

**Adjusting the Clutch Gap**

With only the thrust bearing installed push the bell housing in, and on to the clutch shoe and measure the distance between the outer edge of the black thrust bearing carrier and the top of the bell housing.

This is measurement **A**

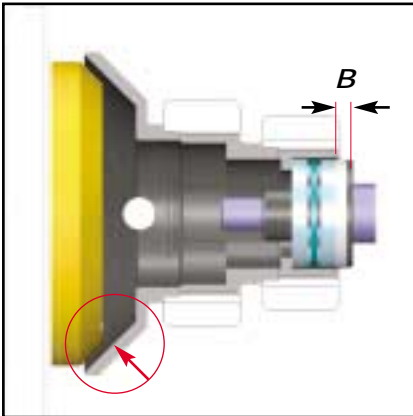

Now pull the clutch housing away from the clutch shoe and against the thrust bearing. Measure the distance between the outer edge of the black thrust bearing carrier and the top of the bell housing again.

This is measurement **B**

The correct clutch spacing is 0.7mm

Calculate the thickness of the required shims as follows:  
 $A - B - 0.7\text{mm} = \text{Thickness of shims required}$

For example:  $A = 1.3\text{mm}$  and  $B = 0.3\text{mm}$   
 Shim thickness =  $1.3 - 0.3 - 0.7 = 0.3\text{mm}$

These shims should be placed before the thrust bearing on the thrust bearing carrier as shown.

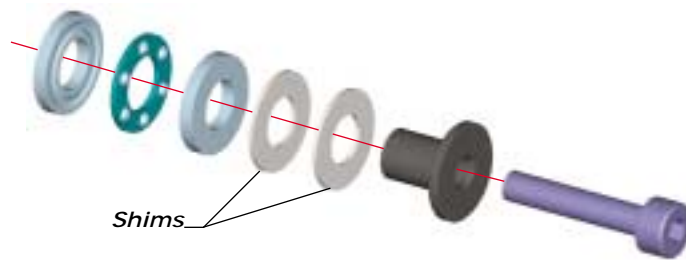

**M14**  
 5x10x0.1mm  
 5x10x0.3mm



**U4**  
 5x10mm



**U45**  
 5x13mm

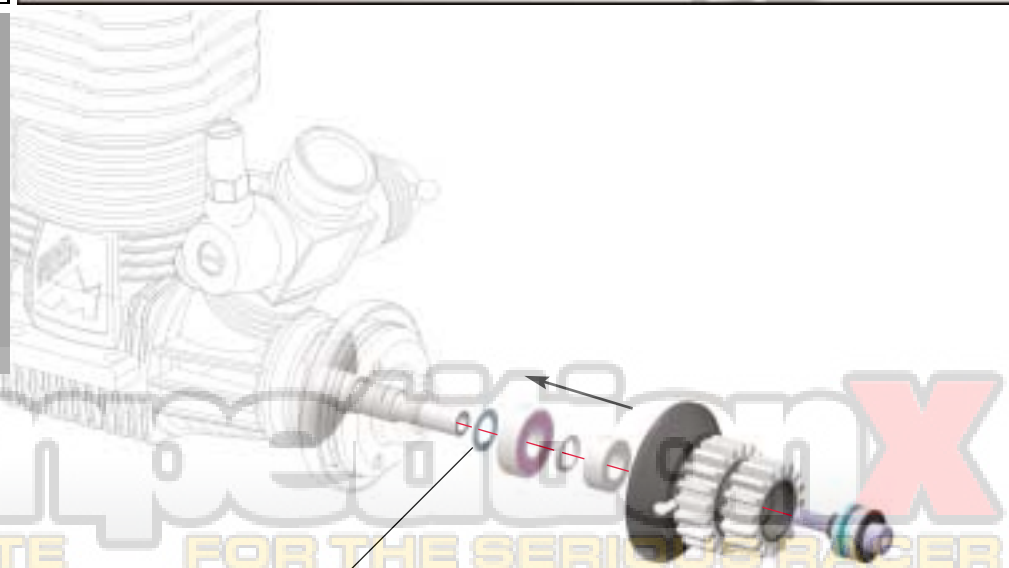

Place small shims to remove all but a small amount of end play



# 9.0 Final Assembly

## Step 9.1

Bag 37(2wd),  
38(4wd)

835 Final Assembly

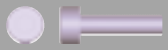

F13  
3x12mm

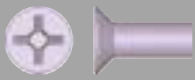

G27  
M5x12mm

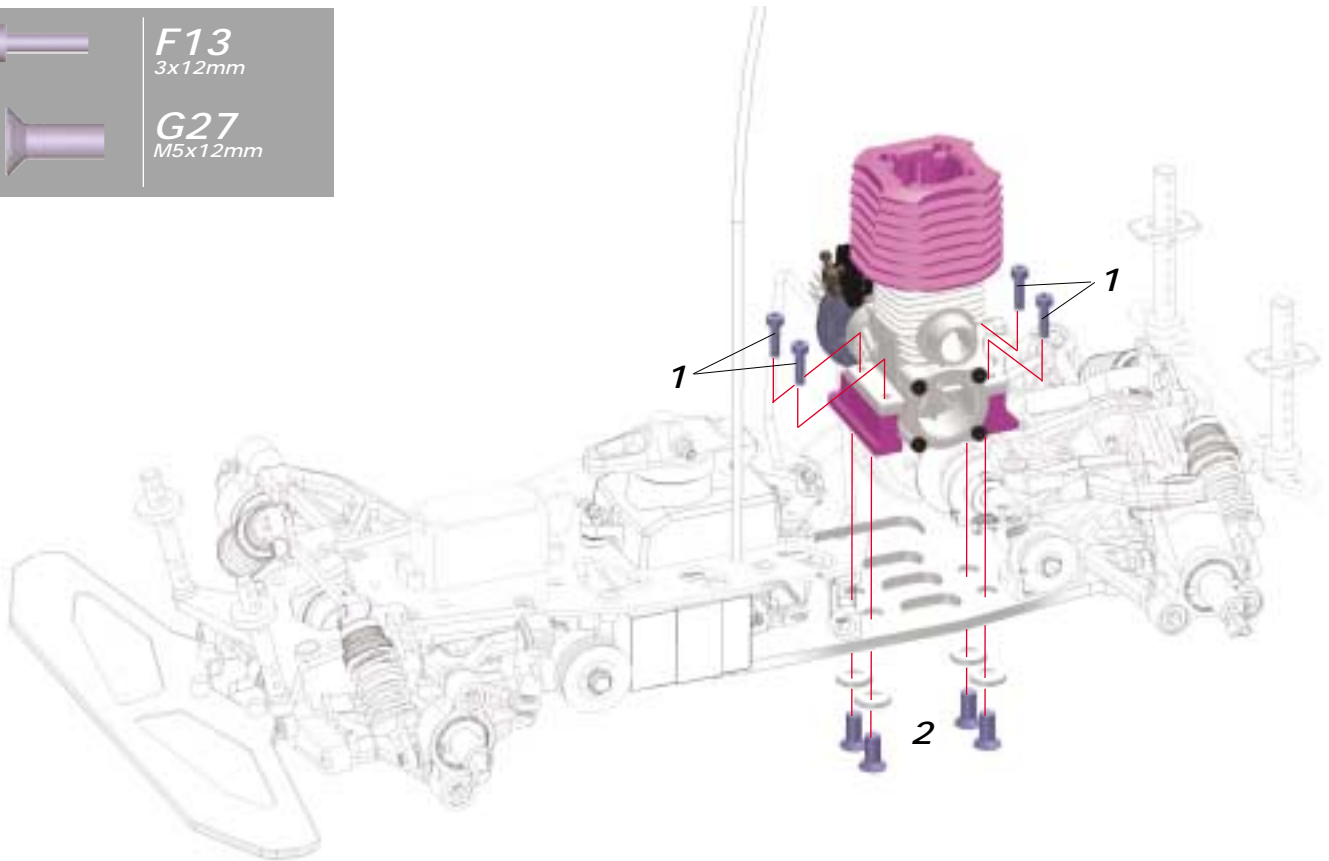

## Step 9.2

835 Final Assembly



E14  
3x16mm



G20  
M4x12mm

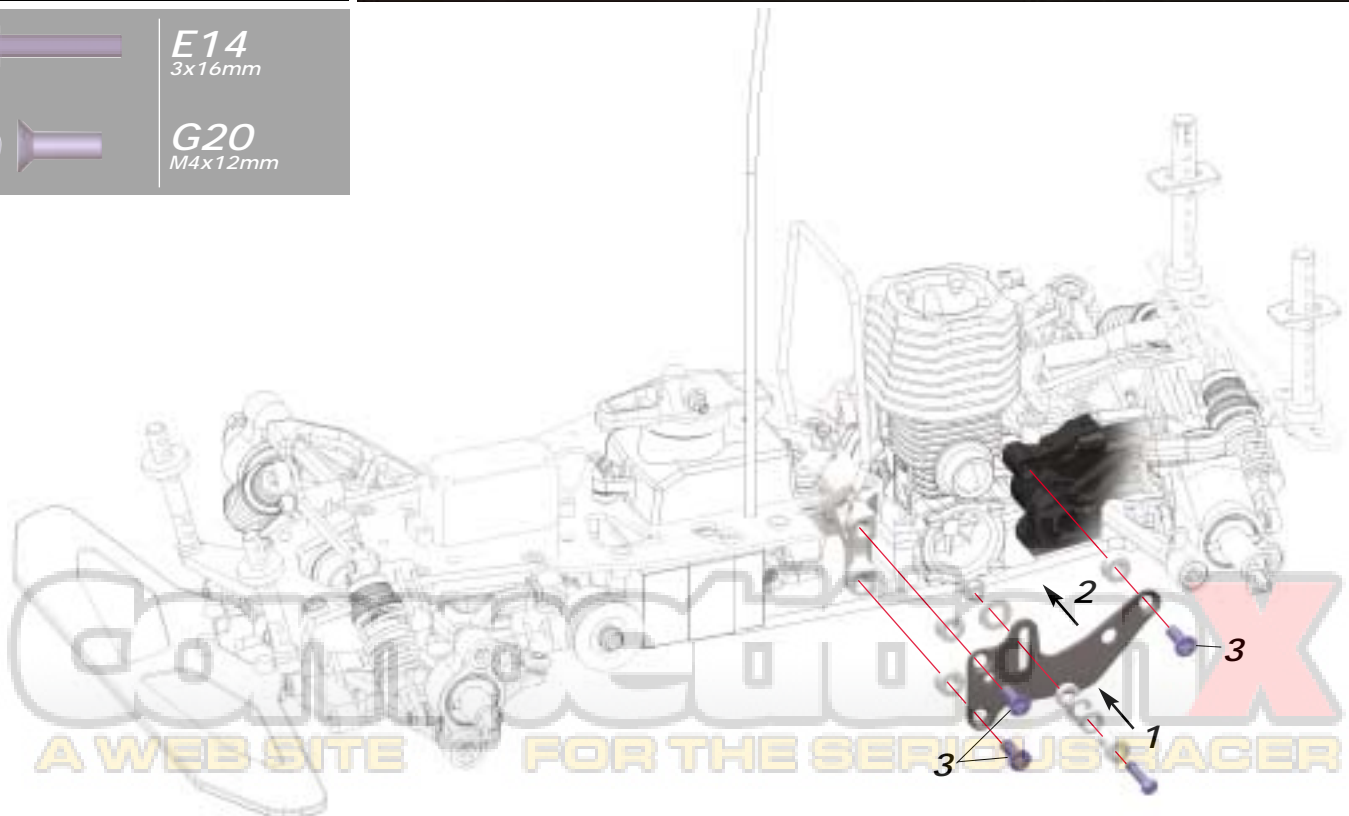



H9  
3x4mm

Cut the throttle rod to your desired length.  
Bend both rods to best suit your requirements.

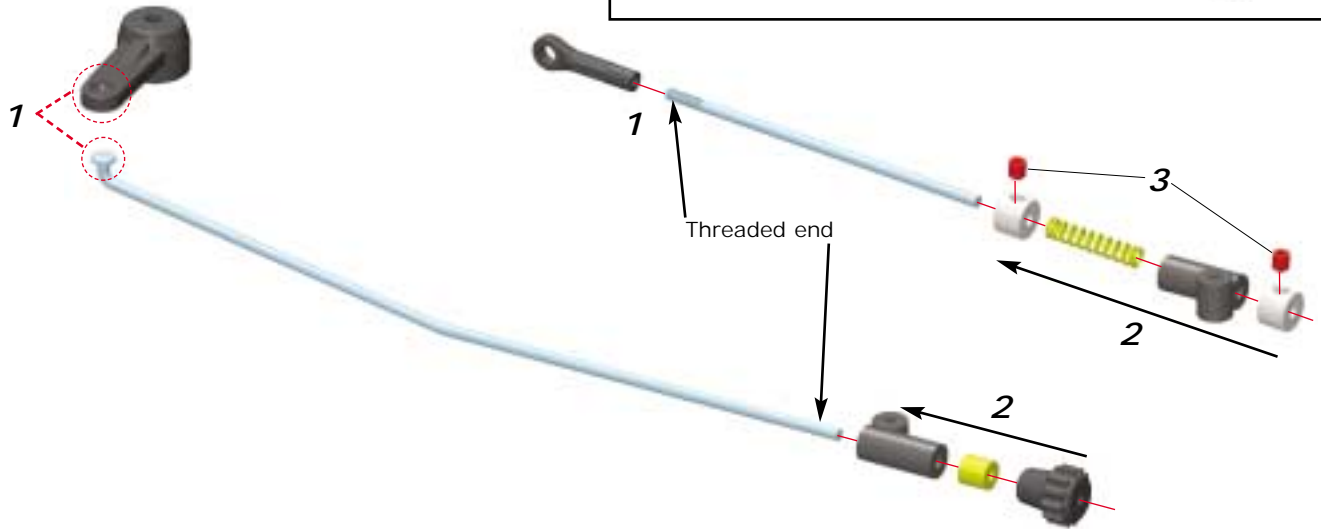
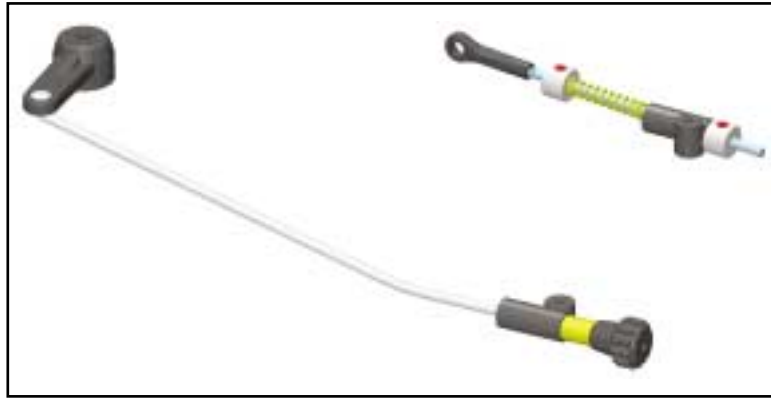

C5  
2.5x8mm

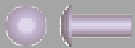

E11  
3x8mm

On the servo arm is a number that corresponds to the amount of teeth.  
23 - Sanwa / KO / JR  
24 - Hitec  
25 - Futaba

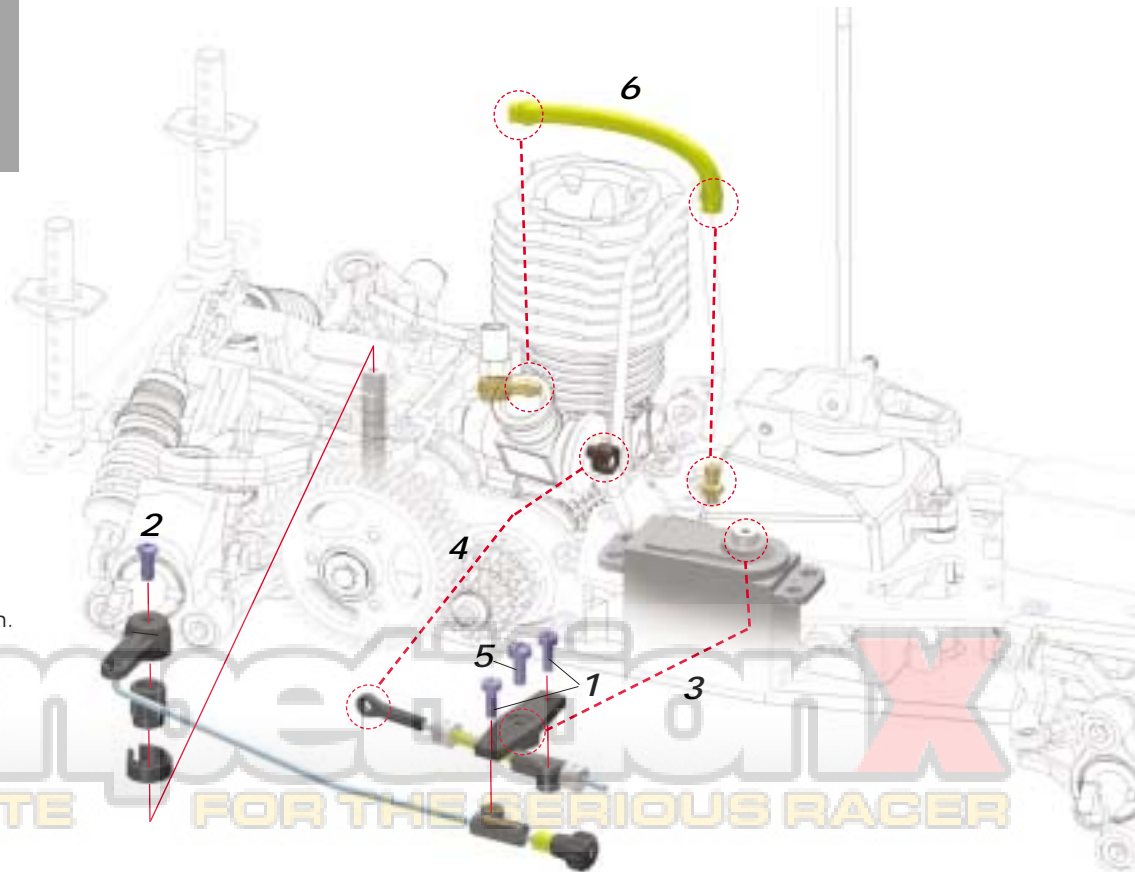

Step 9.5

Bag 41 (2wd),  
42 (4wd)

835 Front Assembly



H17  
4x6mm

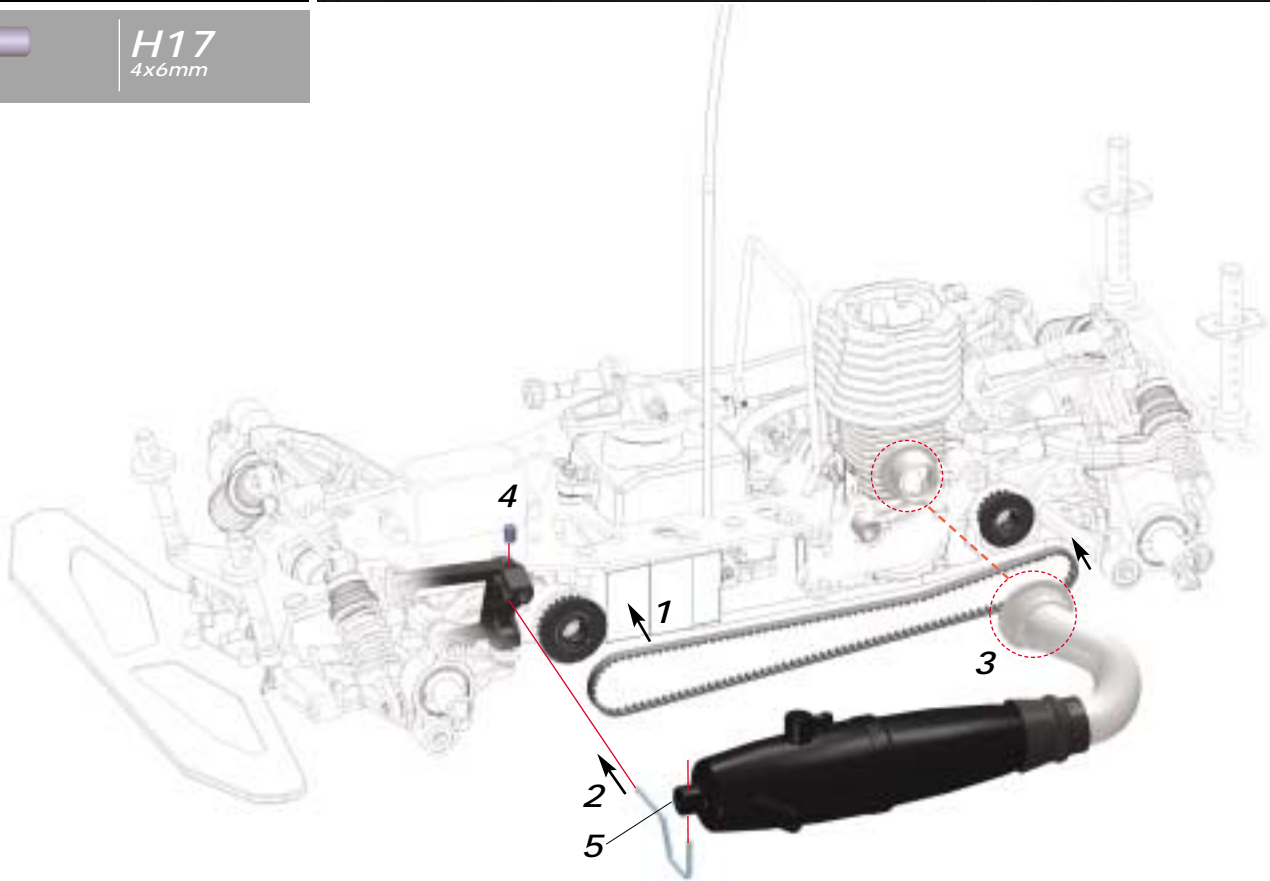

Step 9.6

835 Front Assembly

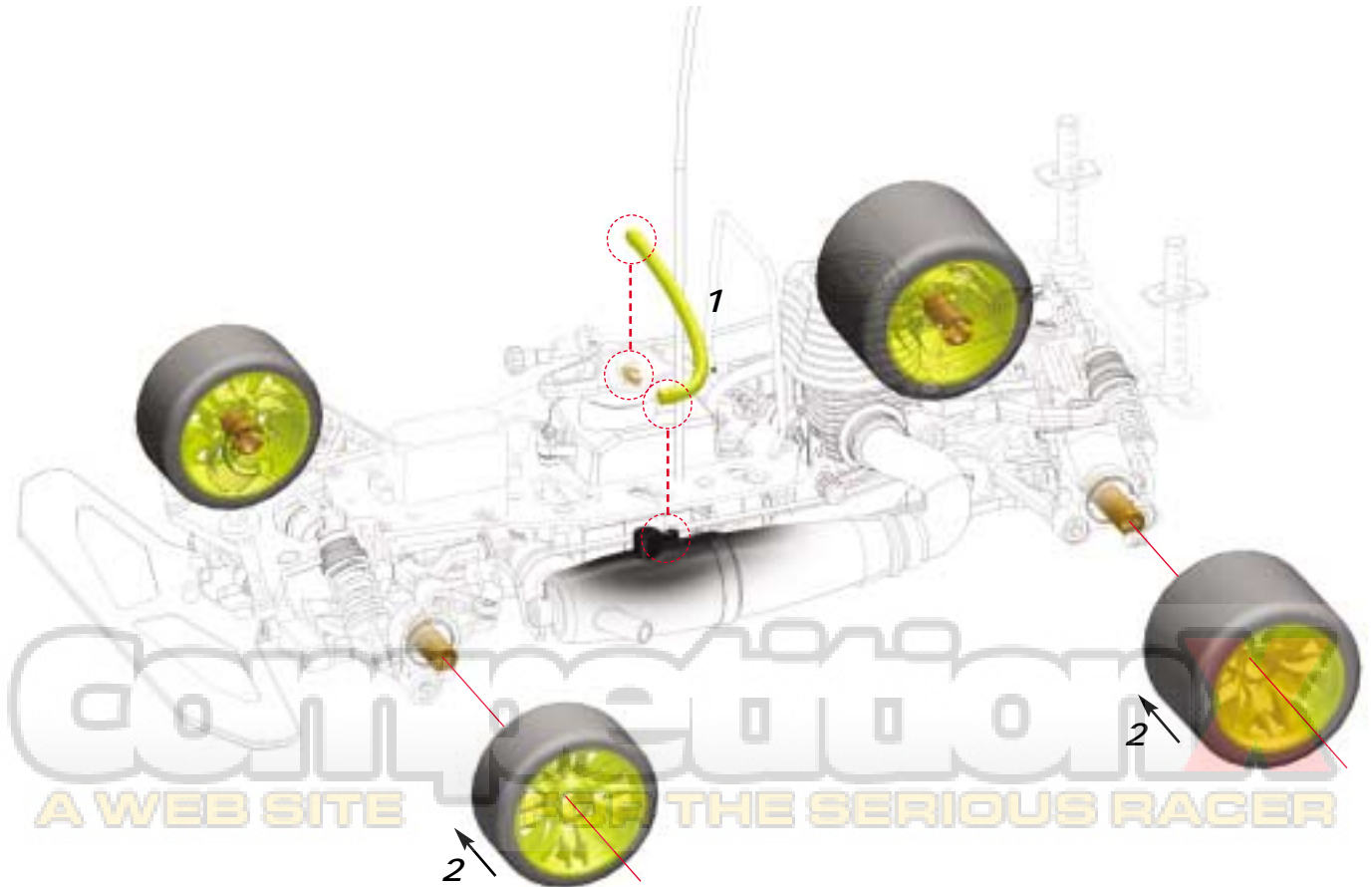

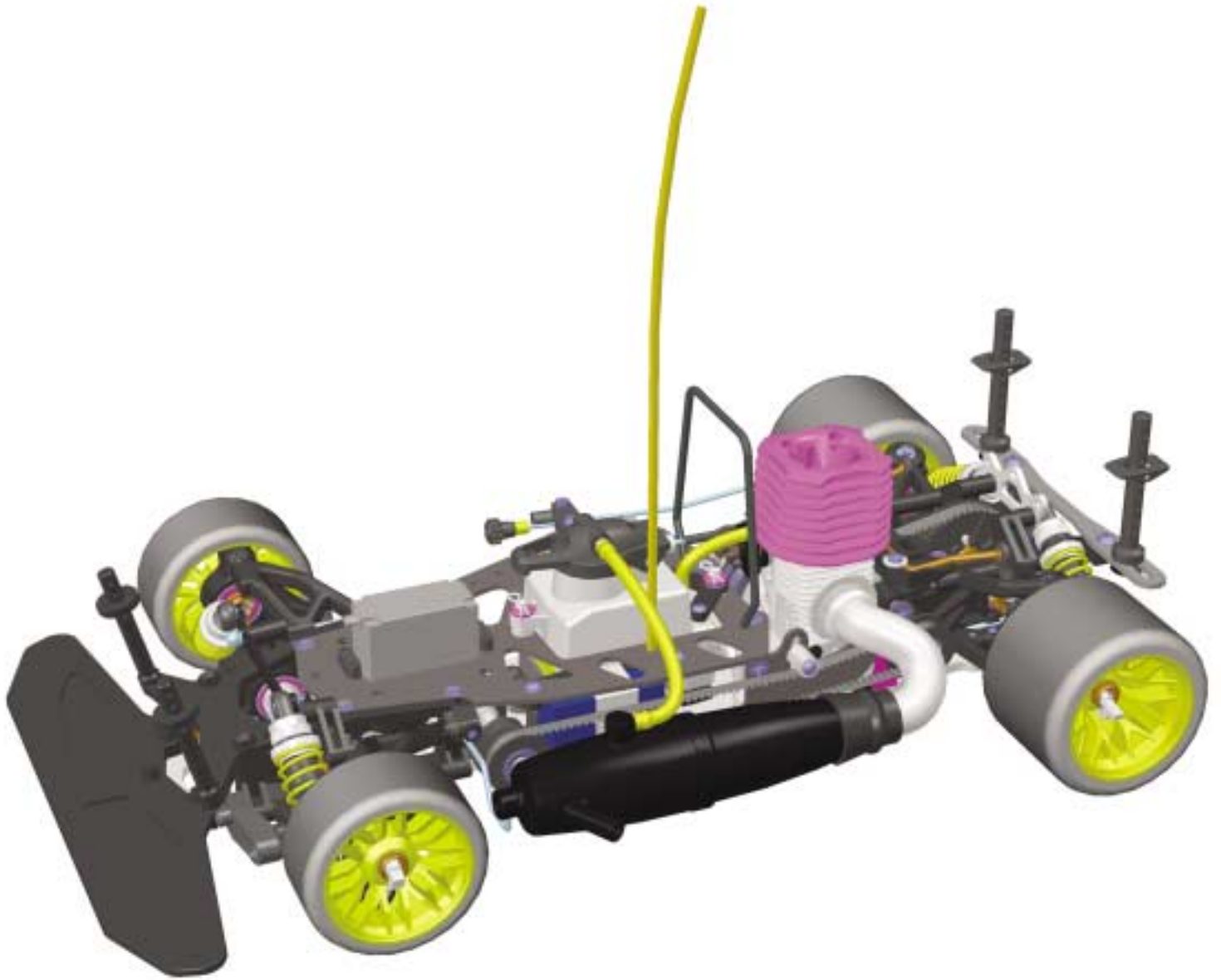

**CompetitionX**  
A WEB SITE FOR THE SERIOUS RACER

# 9.0 Setup Guidelines

Setting up a racecar with fully independent suspension, like your Serpent 835, is necessary to make the car perform well. We have developed these straightforward procedures to help you set up your car properly and easily. Always follow these procedures step-by-step, in the order presented, and always make sure that you make equal adjustments on both left and right sides of the car.

The set-up described here is a good starting point, but you may adjust the settings to better suit different track conditions. Make only small adjustments at a time, and see if you find any improvement in handling with each adjustment. We advise you to keep track of your set-up changes, and record which set-ups work best at different racetracks under various conditions. After rebuilding the chassis, or in case you are lost with your set-up, always return to the set-up described here.

## 1 Shock absorbers

Shock absorber dampening influences the responsiveness of the chassis during cornering (chassis roll), and helps to maintain proper contact between the tire and the road surface during vertical movement. Setting the right dampening is therefore always a compromise and requires a lot of "hands on" experience.

No dampening means that the spring rate determines how long it takes for the spring to compress and the suspension to reach a stable position. Dampening only comes into play when the suspension is moving (either vertical chassis movement or because of chassis roll), and loses its effect when the suspension has reached a stable position. When the spring is compressed or decompressed, the shock absorber oil resists this movement. How much it resists depends on the thickness of the oil and how much the flow is restricted (the number of holes in the shock piston) and of the velocity of the piston.

### How to measure and adjust

The Serpent shock absorbers are adjustable from the outside. Pull out the pistonrod and turn it slightly until it locks in the shock-cylinder. By turning the pistonrod clockwise until the end you reach the hardest position (1 hole). Turning it from here anti-clockwise means opening more holes. By feeling the "clicks" you can determine the number of holes in the piston.



#### 1.1 Front shock absorber setting

Adjust the front shocks to 2 holes (complete turn clockwise, then 1 click back)

#### 1.2 Rear shock absorber setting

Adjust the rear shocks to 3 holes (complete turn clockwise, then 2 clicks back)

## 2 Track-width

Track-width affects the car's handling and steering response. Increasing front track-width will result in more understeer, while decreasing it will result in less understeer and faster steering response.



### 2.1 Front track-width - Setting

Front track-width is measured on the outside of the wheels. It is important that the front track-width is adjusted symmetrically,

meaning that the right and left wheels must be the same distance from the center-line of the chassis.

Set the front track-width to 226mm. Turn both pivot balls IN equally to reduce track-width, turn them both OUT equally to increase track-width.



## 3 Downstops

Downstops limit how far the suspension arms travel downward (which determines how far upwards the chassis travels). The amount of downward suspension travel affects the car's handling, and the effect may change with the type of track and/or amount of grip available. In general, more suspension travel (less downstop) makes the car more responsive but less stable. It is also better on a bumpy track.

**It is very important to adjust the downstops such that left and right sides are equal.**

### How to measure

You check the downstops with the chassis elevated above a reference surface. A special, flat reference board is available from HUDY (#108200 Flat Set-up Board). We also advise you to use the downstop measuring set from HUDY.



Using the measuring gauge, measure the distance from the reference surface to the bottoms of the rear uprights / front steering blocks. Positive numbers indicate the distance (in mm) ABOVE the level of the elevating blocks (or, above the bottom of the chassis). Negative numbers indicate the distance (in mm) BELOW the level of the elevating blocks (or, below the bottom of the chassis).

### Perform these initial steps

**A** Remove the wheels from the car.

**B** Front anti-roll bar: Remove screw from the right front anti-roll bar mount to disconnect it.

**C** Rear anti-roll bar: Disconnect one ball-joint from rear anti-roll bar.



*Remark:* it is not necessary to remove the shocks, however you must be sure that they are long enough not to limit the suspension. Be sure the suspension is reaching the downstop limits, before the shocks do.

#### 3.1 Downstops front

Adjust the front downstop screws so that the bottoms of the steering blocks are at 0mm on the gauge. (Actual measurement = 0 mm above level of elevating blocks, or level with the bottom of the chassis).



#### 3.2 Downstops rear

Adjust the rear downstop screws so that the bottoms of the rear uprights are at +7mm on the gauge. (Actual measurement = 7mm above level of elevating blocks, or above the bottom of the chassis).



## 4 Ride Height

Ride-height also affects the car's traction as it moves the center of gravity and the roll-center of the car. Decreasing the ride-height (lowering the car) gives you more grip. However, because of changes in suspension geometry and decreasing ground clearance, there are also negative consequences to doing this.

### How to measure

The cars ride height is measured when mounted on the HUDY setup system or using a set of 67mm rear / 64mm front tires. Measure using a HUDY ride height



gauge or calipers from the very end point at both the front and rear of the car.

#### 4.1 Front ride height - Setting

Set the front ride height to 7mm. This is done by adding or removing pressure on both front springs pre-tension and therefore raising or lowering the ride height.

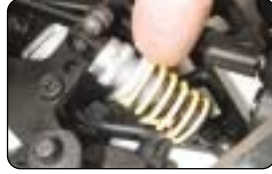

#### 4.2 Rear ride height - Setting

Set the rear ride height to 7mm. This is done by adding or removing pressure on both rear springs pre-tension and therefore raising or lowering the rider height.



#### 5.0 Camber

Camber is the angle of a wheel to the surface when the car is resting on the surface (with wheels and shock absorbers mounted). Zero degrees (0°) of driving camber means that the wheel is perpendicular to the reference surface; negative degrees means that the top of the wheel is leaning inwards; positive degrees means that the top of the wheel is leaning outwards.

Camber affects the car's traction. In general, more negative camber means increased grip. Nevertheless, it should always be adjusted such that the front tires wear flat, while the rear tires should wear slightly conical to the inside.

#### 5.1 Front driving camber - Setting

Adjust the front driving camber to -1.5 degrees (tops of front wheels leaning inwards).

##### How to measure

Before measuring front driving camber, lift and drop the front end of the car a few cm's to let the suspension settle. Measure the camber using the Hudy set-up system which you already used to adjust ride height.



*Notice:* using wheels together with a camber gauge may result in noticeable different camber readings. The reason is that especially the rear tire has a tendency to lay flat on the surface. If then i.e. the tire is not pre-coned, the camber reading may differ up to 1 degree less camber to the reading you get with the Hudy system.

##### How to adjust

Camber is adjusted by turning the pivot-balls in or out. Turning the upper pivot-ball in while turning the lower one out gives more negative camber. Always turn one pivotball in and the other one out, otherwise you will change toe-in.



#### 5.2 Rear driving camber - Setting

Adjust the rear driving camber to -2.5 degrees (tops of rear wheels leaning inwards).



##### How to measure

The measuring is similar to the front camber.

##### How to adjust

Camber is adjusted by turning the pivot-balls in or out. Turning the (lower) pivot-balls out gives more negative camber. Always turn both pivotballs in or out, otherwise you will change toe-in.



#### 6 Toe-in

Toe-in is the angle of the wheels when looked at from above. When the wheels are parallel, the toe-in is 0 degrees. When the wheels are open towards the front, this is called toe-out (or negative toe-in). When the wheels are closed towards the front, this is called (positive) toe-in.

Toe-in is used to stabilize the car. In the case of oversteer (the rear end losing traction before the front), adding extra rear toe-in may help, but this makes on-power cornering a little more difficult. If the car is too stable and pushing (understeering), removing some front toe-in will remedy this.

##### How to adjust

Front toe-in is adjusted with the track-rods that connect the servosavers to the steering blocks. Making the track-rods longer will create more toe-in, while making them shorter will create less toe-in.

To create more rear toe-in, turn in the front pivot ball and turn out the rear pivot ball. To create less rear toe-in, turn out the front pivot ball and turn in the rear pivot ball. Remember to make equal (but opposite) adjustments to the pivot balls.



##### How to measure

Measure both the front and rear toe-in using the set-up tool from HUDY

#### 6.1 Front Toe-in - Setting

Adjust the front toe-in to -0.5 degrees (fronts of front wheels pointing slightly outwards).



#### 6.2 Rear Toe-in - Setting

Adjust the rear toe-in to +2.0 degrees (fronts of rear wheels pointing inwards).



#### 7 Caster angle

Caster angle is the angle of an imaginary line between the top pivot ball and the bottom pivot ball of the steering block, with respect to a line perpendicular to the ground. Caster angle affects on- and off-power steering, as it will tilt the chassis more or less depending on how much caster is applied.

In general changing caster has an effect on on-throttle handling. Giving more caster results in more on throttle oversteer (or less understeer). Effects on off-throttle balance is quite little and difficult to predict.

##### How to adjust

The caster angle is adjusted with nylon spacers which are inserted either in front of or behind the upper front suspension arm. More spacers in front of the arm will increase the caster angle. More spacers behind the arm will decrease the caster angle.

#### 7.1 Caster - Setting

Set the front caster gap to 2mm (2mm shim in front of the upper arm, 1+4mm shims behind).

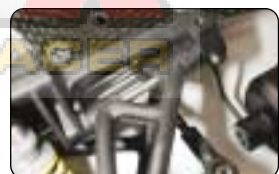

## 8 Checking for suspension tweak

A "tweaked" car is an unbalanced car, and has a tendency to pull to one side under acceleration or braking. Tweak is caused by an uneven wheel-load on one particular axle. Now that the suspension geometry set-up has been completed, you must check for suspension tweak before you reconnect the anti-roll bars.

### Perform these initial steps:

**A** Place the car on a flat reference surface.

**B** Make sure that both front and rear anti-roll bars are disconnected.

**C** Put a set of good tires on the car, important is that the left wheels have the same size than the right ones

**8.1** Checking for tweak from the front of the car. Lift and drop the front end of the car a few cm's to let the suspension settle. Place a sharp tool underneath the chassis at its middle point, and lift the front end. If one front wheel lifts before the other, the rear of the car is tweaked.



**8.2** Adjust the preload on the rear springs until both front wheels lift at the same time. If, for example, the front right wheel lifts earlier, you must increase the preload on the rear left spring, and decrease the preload on the rear right spring. You must adjust both rear springs, otherwise you will change the ride height.



**8.3** Reconnect the rear anti-roll bar, and check for tweak again by lifting the front end of the car. If again one front wheel lifts before the other, the rear anti-roll bar is tweaked. Adjust the length of one or both rear anti-roll bar pushrods until both front wheels lift at the same time.



**8.4** Checking for tweak from the rear of the car. Lift and drop the rear end of the car a few cm's to let the suspension settle. Place a sharp tool underneath the chassis at its middle point, and lift the rear end. If one rear wheel lifts before the other, the front of the car is tweaked.



**8.5** Adjust the preload on the front springs until both rear wheels lift at the same time. If, for example, the rear right wheel lifts earlier, you must increase the preload on the front left spring, and decrease the preload on the front right spring. You must adjust both front springs, otherwise you will change the ride height.

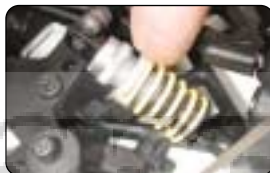

**8.6** Reconnect the front anti-roll bar, and check for tweak again by lifting the rear end of the car. If again one rear wheel lifts before the other, the front anti-roll bar is tweaked. Loosen the screw on the left front anti-roll bar mount. Adjust the eccentric cam until both rear wheels lift from the ground at the same time. Tighten the screw to secure the adjusting cam.



## 9 Anti-roll bars

Anti-roll bars are used to adjust the car's side-traction. In general, increasing the hardness of an anti-roll bar on one particular axle decreases the side-traction of that axle and increases the side-traction of the other axle. For example, if you make the front anti-roll bar harder, you decrease the side-traction of the front and increase the side-traction of the rear. This will result in less steering (more understeer).

Changing the front anti-roll bar has more effect on turning-in (entering a turn, decelerating, off-power).

Changing the rear anti-roll bar has more effect on powering-out (exiting a turn, accelerating, on-power).



### How to adjust

You adjust the front anti-roll bar by turning both blades to an equal angle. The flat of the blade in a horizontal position is the softest position; the vertical position is the hardest position.

### 9.1 Front anti-roll bar - Setting

Adjust the front anti-roll bar to the (softest) horizontal position (0 degrees).

**9.2** The rear anti-roll bar is non adjustable but you can obtain a 3mm version (#909330).

**www.racingtonx.com**  
A WEB SITE FOR THE SERIOUS RACER

**myTSN.com** 

*[www.myTSN.com/Serpent835](http://www.myTSN.com/Serpent835)*

**SERPENT  
MOTORSPORT**

P.O. Box 180, 2100 AD Heemstede  
The Netherlands, Europe.  
Tel: (31) 23 529 2068  
Fax: (31) 23 528 4950  
E-mail: [info@serpent.com](mailto:info@serpent.com)

**Serpent USA, Inc.**  
West Park Center,  
2830 NW 79th Avenue,  
Miami, Florida 33122, USA.  
Tel: (305) 639 9665  
Fax: (305) 639 9658  
E-mail: [info@serpent-usa.com](mailto:info@serpent-usa.com)

**Impetition X**  
B SITE FOR THE SERIOUS RACER