

Name: _____
Date: _____
Track: _____

Track Conditions

Size:	Open	Med.	Tight
Traction:	High	Med.	Low
Surface:	Smooth	Med.	Bumpy

Front Suspension

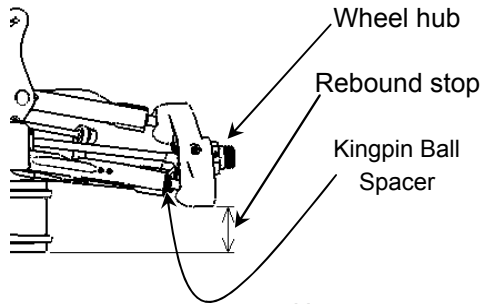

- Kingpin ball spacer _____ mm
- Camber angle _____ °
- Upper arm spacer _____ mm
- Toe angle _____ °
- Rebound stop _____ mm
- Anti-roll bar φ _____ mm
- Wheel Hub _____ mm
- Lower arm mount (Kick up) _____



- Lower arm plate (E0154A)

- Upper arm position (E0148B, E0148C)

- Lower arm spacer _____ mm

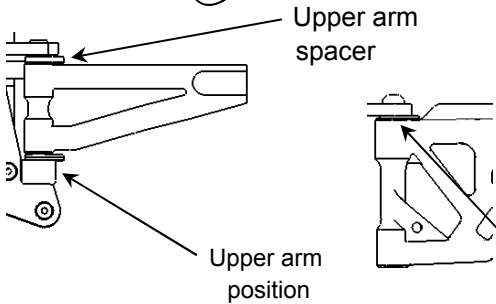

Front Shocks

- Piston _____
- Oil # _____
- Spring _____
- Spring adjustment _____ mm
- Shock position

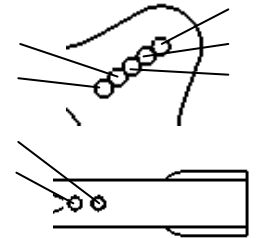

Steering Ackerman



Rear Suspension

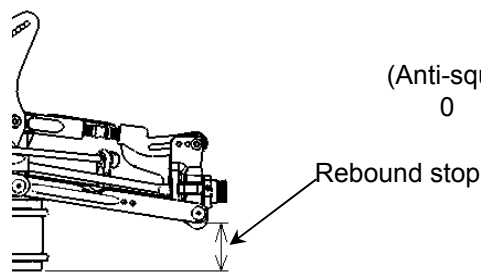

- Camber angle _____ °
- Lower arm mount _____
- (Anti-squat) 0 1
- (Toe angle) _____ °
- Rebound stop _____ mm
- Anti-roll bar φ _____ mm
- Anti-squat (E0111C, E0111D) _____



- Upright E0152
- E0173 (Aluminium)
- Wheelbase adjustment _____ mm

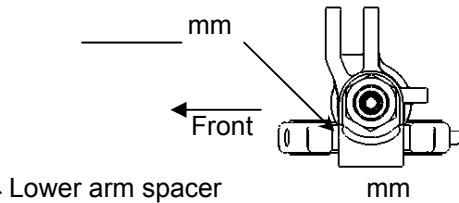
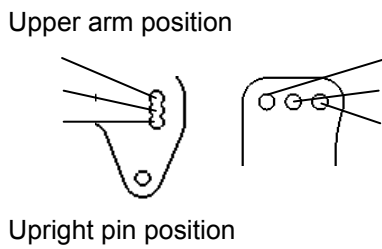

Rear Shocks

- Piston _____
- Oil # _____
- Spring _____
- Spring adjustment _____ mm
- Shock position

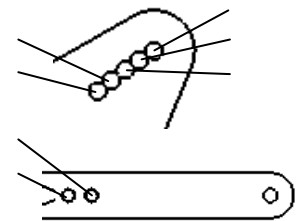

Wing Position

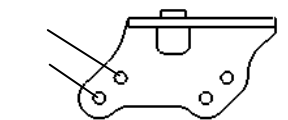

Engine

Type	_____	Reducer	φ _____
Gasket	_____ mm	Fuel	_____
Plug	_____		
Muffler	_____		

Diff. Oil

Front	# _____	O-Ring	_____ pcs.	Other	_____
Center	# _____		_____ pcs.	Other	_____
Rear	# _____		_____ pcs.	Other	_____

Tire

Front	Rear
Type _____	Type _____
Foam _____	Foam _____

Clutch

Clutch shoes	Aluminium _____
	Other _____
Spring	_____ mm
Clutch bell / Spur gear	T / T

Result

Race time / Lap _____

Best lap (1Lap) _____

Comments:

.....

.....

.....

.....