

Driver: \_\_\_\_\_

Track: \_\_\_\_\_

Date: \_\_\_\_\_

Surface: \_\_\_\_\_

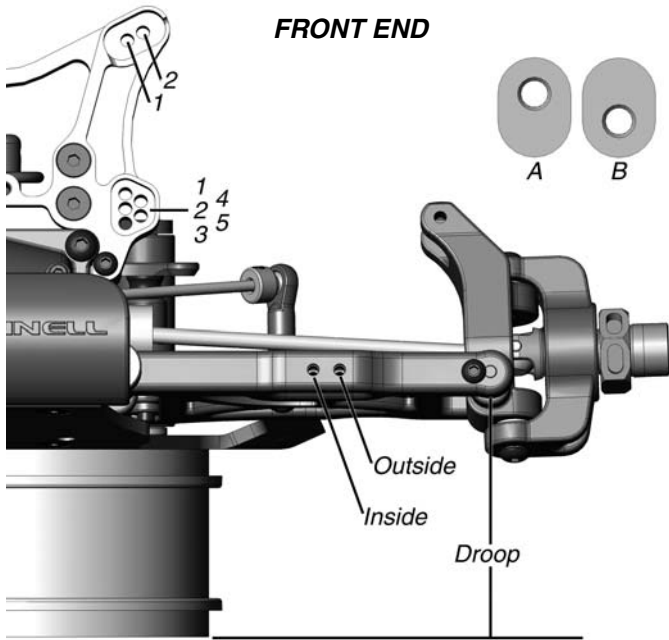

**FRONT END**

Oil: \_\_\_\_\_

Spring: \_\_\_\_\_

Piston: \_\_\_\_\_

Sway Bar: \_\_\_\_\_

Camber: \_\_\_\_\_

Toe: \_\_\_\_\_

Lower Caster Block Eccentric Bushing: \_\_\_\_\_

Inner Camber Link: \_\_\_\_\_

Upper Shock Placement: \_\_\_\_\_

Lower Shock Placement: \_\_\_\_\_

Droop: \_\_\_\_\_

Ride Height: \_\_\_\_\_

Bump Steer Spacers: \_\_\_\_\_

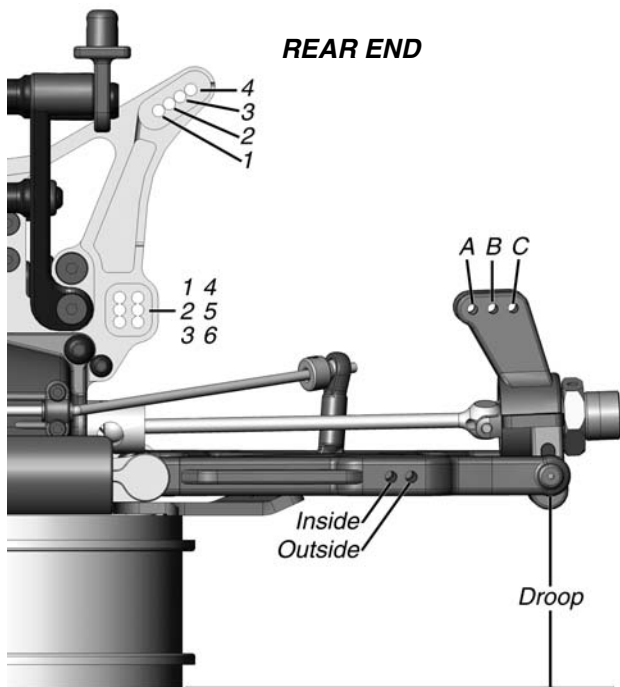

**REAR END**

Oil: \_\_\_\_\_

Spring: \_\_\_\_\_

Piston: \_\_\_\_\_

Sway Bar: \_\_\_\_\_

Camber: \_\_\_\_\_

Inner Camber Link: \_\_\_\_\_

Outer Camber Link: \_\_\_\_\_

Rear Toe-In: \_\_\_\_\_

Rear Anti-Squat: \_\_\_\_\_

Hub Carrier Placement: \_\_\_\_\_

Upper Shock Placement: \_\_\_\_\_

Lower Shock Placement: \_\_\_\_\_

Droop: \_\_\_\_\_

Ride Height: \_\_\_\_\_

Wing Position: \_\_\_\_\_

**DIFF OILS:**

**CLUTCH**

**GEARING**

**SWAYBAR LEGEND**

**SPRING LEGEND**

Front: \_\_\_\_\_

Shoes: \_\_\_\_\_

Spur: \_\_\_\_\_

A: .093

Blue (Softest)

Center: \_\_\_\_\_

Material: \_\_\_\_\_

Clutch Bell: \_\_\_\_\_

B: .100

Gray

Rear: \_\_\_\_\_

Springs: \_\_\_\_\_

C: .105

Silver (Hardest)

**Note:** Ride height is measured at the back of the chassis for the rear and at the bellcrank screws for the front.