

Name : **Carlos Macias**
 Date : **8/31/08 Riverfront**
 Track : **RC Marysville, CA.**

Track Conditions

- | | | | |
|------------------------------------|---------------------------------|--|---|
| <input type="checkbox"/> Size: | <input type="checkbox"/> Open | <input checked="" type="checkbox"/> Med. | <input type="checkbox"/> Tight |
| <input type="checkbox"/> Traction: | <input type="checkbox"/> High | <input checked="" type="checkbox"/> Med. | <input type="checkbox"/> Low |
| <input type="checkbox"/> Surface: | <input type="checkbox"/> Smooth | <input type="checkbox"/> Med. | <input checked="" type="checkbox"/> Bumpy |

Front/Rear Suspension

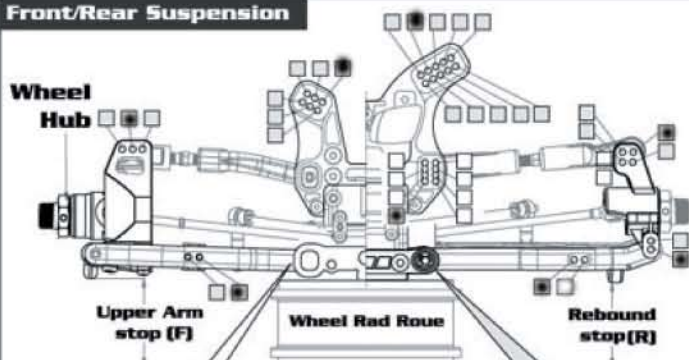

Camber angle : F **-2** °
 R **-2** °
 Toe angle **+1** °
 Rebound stop : F **Full** mm
 R **Full** mm
 Anti-rollbar : F **KS** mm
 R **KS** mm

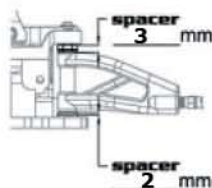

Front Shocks

Piston **Kyosho FL Green**
 Oil # **40 Losi**
 Spring **KS**

Rear Shocks

Piston **KS**
 Oil # **30 Losi**
 Silver Stock
 Spring

Wing Position



Steering Ackerman

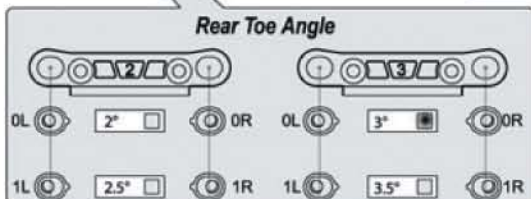
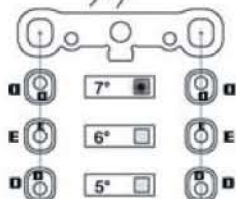

Front Suspension

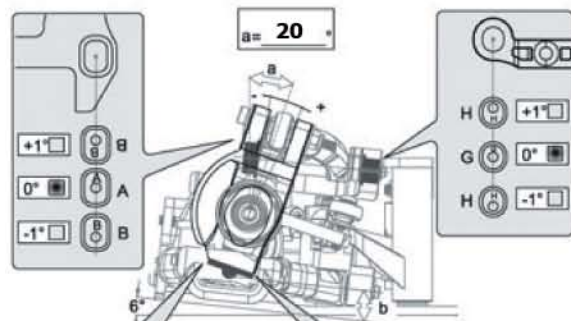

Left Side

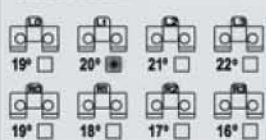

Right Side

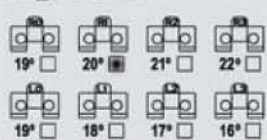

Rear Suspension

- CNC Rear Hub Carriers
- CNC Rear Toe Plate 3 degree
- CNC 1 Peice Engine Mount.

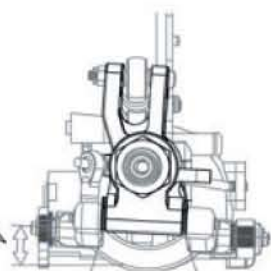
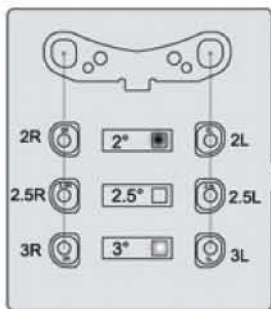

Wheelbase adjustment

- Ride Height
- Rear Drive Axles Level
- Front Drive Axles Slightly Below level

Engine

Type **Modified V-Spec**
 Gasket _____ mm Reducer Ø _____
 Plug **P3** Fuel **Werks 30%**
 Muffler **JP-3**

Diff. Oil

Front # **4000** Center # **5000** Rear # **1000**

Tire

Stock Spoke Wheels Front & Rear
 Front Type **Bowtie M3** Rear Type **Bowtie M3**
 Foam **Stock** Foam **Stock**

Clutch

Clutch shoes Aluminium Other **Mugen Carbon**
 Spring **Kyosho 1.1** mm
 Clutch bell/Spur gear **13 / 46**