

Name: John Bernard Jr. Date: 4/26/2014 Event/Track: ROTORS, RUDDERS, AND WHEELS



Track Conditions: Outdoor Indoor Wet Dry High Bite Low Bite Rough
 Smooth Hard Packed Loose/Loamy Blue Groove

Bumpsteer/Ackerman/Servo Saver/Steering Stop:

 <p># washers <input type="text" value="4"/> over <input type="text" value="0"/> under ballstud <input type="checkbox"/></p>	 <p># washers <input type="text" value="4"/> over <input type="text" value="0"/> under ballstud <input checked="" type="checkbox"/></p>	 <p><input type="checkbox"/> front <input checked="" type="checkbox"/> middle <input type="checkbox"/> rear</p>
---	---	--

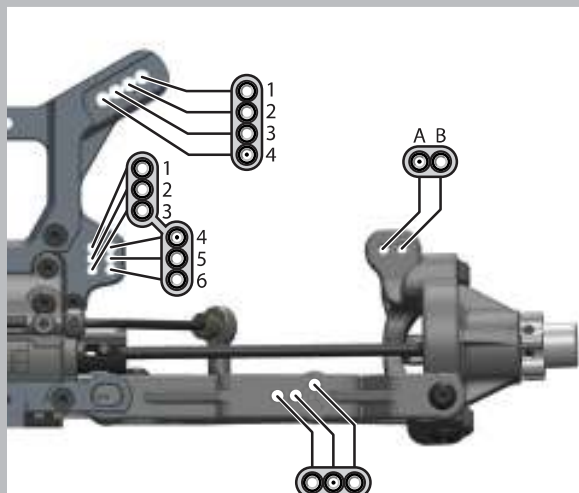
Front End:



 <p># of turns from fully tightened <input type="text" value="4"/></p>	 <p># washers <input type="text" value="4"/></p>
--	---

Suspension:

	FRONT	REAR
RIDE HEIGHT:	27MM	28MM
TOE (in/out):	2° OUT	4° IN
CAMBER:	-1°	-1°
CASTER:	15° Deg°	
SHOCK LENGTH (DROOP):	105.5MM	122MM
SWAY BAR:	2.5MM	2.5MM

NOTES:

Body/Wing:

BODY:	STOCK
WING:	JC FINNISHER WITH GURNEY

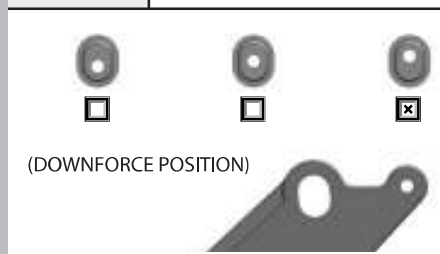

Wheelbase:

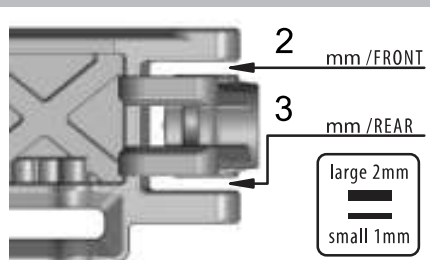

Notes:

ambient temp 90°, medium bite

	FRONT	REAR
STD/EMUL/VENT:	VENTED	VENTED
PISTON:	8X1.3	8X1.3
OIL:	AE 40	AE 35
BLADDER:	STOCK	STOCK
REBOUND:	17.5MM %	17.5MM %
SPRING:	PINK	RED

NOTES:

Tires / Wheels:

	FRONT	REAR
BRAND:	JC	JC
TREAD:	STACKER	STACKER
COMPOUND:	GREEN	GREEN
INSERT:	STD	STD
WHEEL:	MONO	MONO

NOTES:

Differential Oil:

	FRONT	CENTER	REAR
7K	7K	5K	

NOTES:

Equipment:

ENGINE:	GO 5-PORT
PIPE	JAMMIN JP-4
PLUG:	P3
FUEL:	BYRON'S 30% (11)
RX BATT:	Trinity 2500mah Lipo
SERVO:	steering RP Signature / throttle/brake RP Signature

Drivetrain:

CLUTCH/SPUR:	15 / 44 (teeth)
CLUTCH SHOES:	stock
CLUTCH SPRINGS:	2x0.9mm, 2x1.0mm
ENGINE POSITION:	Front <input type="checkbox"/> Rear <input checked="" type="checkbox"/>
BRAKE BIAS:	front 50 % rear 50 %

Chassis Braces:

Center Rear Left Rear Right

Front Outer (Sweep)

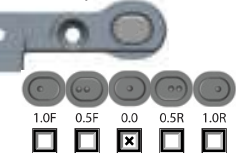

Front Inner (Kick Up)



Rear End:

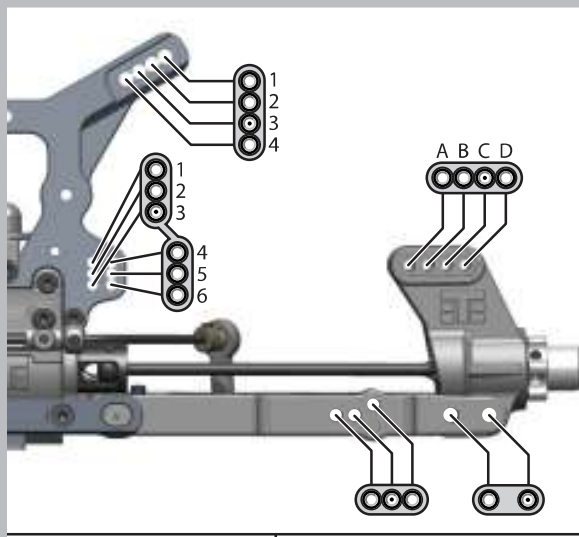

Rear Outer (Toe In)

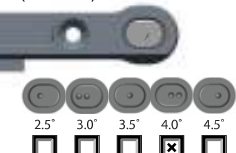

Rear Inner (Anti-Squat)

