

Name: David Lim

Date: 20-01-2008 Event: HD 500 Cup (M'sia)

City: K.L State: \_\_\_\_\_

Track: HPC - Glenmarie

Track  Indoor  Tight  Smooth  Hard Packed  Blue Groove  Wet  Low Bite  High Bite  
 Conditions  Outdoor  Open  Rough  Loose/Loamy  Dry  Dusty  Med Bite  Other \_\_\_\_\_

### Front Suspension

Toe: 1 degree toe-out  
 Ride Height: \_\_\_\_\_  
 Camber: -1 degree  
 Caster: stock (20 degrees)  
 Sway Bar: 2.3 mm (Black)  
 Piston/Oil: 54/45 wt Team Losi  
 Spring: white  
 Limiter/Droop: 96 mm  
 Overall Shock Length: \_\_\_\_\_  
 Steering Ackerman: Long  
 Bump Steer: Down  
 Camber Link: #3  
 Shock Location: #3 / middle  
 Front Diff Fluid: 7000 Team Losi  
 Receiver Battery Type: LRP 1400 mah  
 Center Diff Fluid: 10000 Team Losi

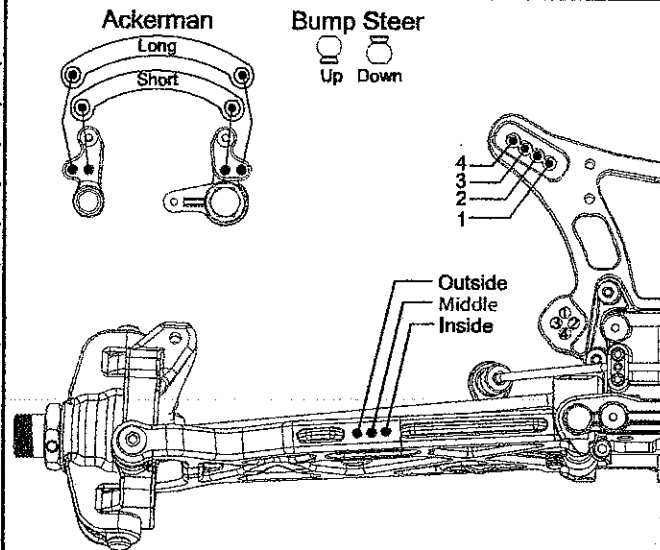

Notes: \_\_\_\_\_  
 \_\_\_\_\_  
 \_\_\_\_\_

### Rear Suspension

Toe: 2.5 degrees  
 Anti-Squat: 3 degrees  
 Ride Height: \_\_\_\_\_  
 Camber: -2 degrees  
 Rear Hub Spacing: All the way Front  
 Sway Bar: 2.3 mm (Black)  
 Piston/Oil: 56/35 wt Team Losi  
 Spring: grey  
 Limiter/Droop: 110 mm  
 Overall Shock Length: \_\_\_\_\_  
 Camber Link: #4/B  
 Shock Location: #4 / inside  
 Rear Diff Fluid: 3000 Team Losi

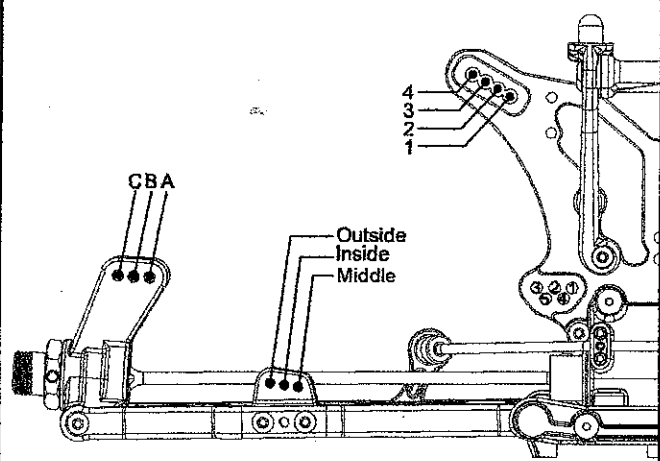

Notes: \_\_\_\_\_  
 \_\_\_\_\_  
 \_\_\_\_\_

### Engine

Engine: Werks B7 Pro (21) Fuel: Werks 30%  
 Glow Plug: O'Donnell 99T Head Clearance: \_\_\_\_\_  
 Pipe/Header: Werks 2013 Gearing: 14/48

### Clutch



Clutch Shoes and Springs Info  
4 Aluminum - silver Springs  
 \_\_\_\_\_  
 \_\_\_\_\_

### Tires

Type	Compound	Insert
Front: <u>Werks Lugs</u>	<u>R 200 (soft)</u>	<u>Foam</u>
Rear: <u>Werks Lugs</u>	<u>R 200 (soft)</u>	<u>Foam</u>

Notes: \_\_\_\_\_  
 \_\_\_\_\_