

NAME **Gabriele Vignolini**
 COUNTRY **Italy**
 RACE **C.I. UISP - Gara 3**
 TRACK **Sesso (RE)**

SETUP SHEET

DATE **17/06/2012** TEMP.°C AIR / TRACK **38°C** / 60°C
 TRACK CONDITION TECHNICAL CARPET ASPHALT
 MIXED FAST
 TRACTION LOW MEDIUM HIGH

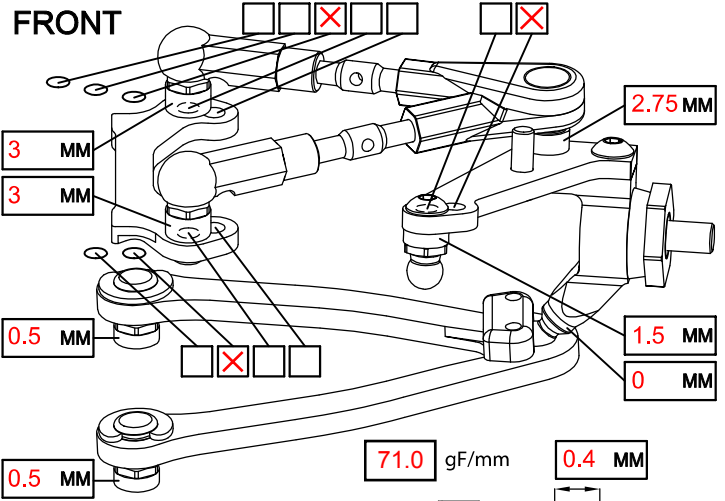

CAMBER ANGLE / ° **-1**
 CASTER ANGLE / ° **4**
 TOE ANGLE / ° **1**
 RIDE HEIGHT / MM **5.2**
 DOWNSTOP / MM **5.6**
 UPSTOP / MM **max**

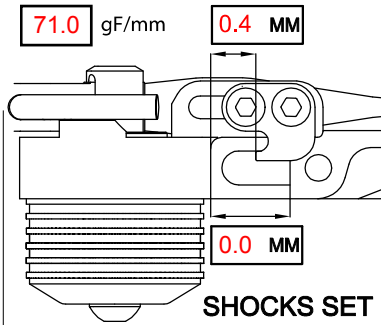

SHOCKS SET

STABILIZER Ø / MM **1.0**
 LOW ARM STD
 STEERING ARM STD
 WHEEL SPACER / MM
 FRONT DRIVE BALL DIFF GEAR DIFF SPOOL ONE-WAY
 DIFF SET LOOSE MEDIUM TIGHT OIL #
 DOGBONE DRIVE BUSHING C-DRIVE BB EVD

SPRING STD
 DAMPER STD
 ACTION SYM. ASYM.
 SRS/RHS ARR. I II

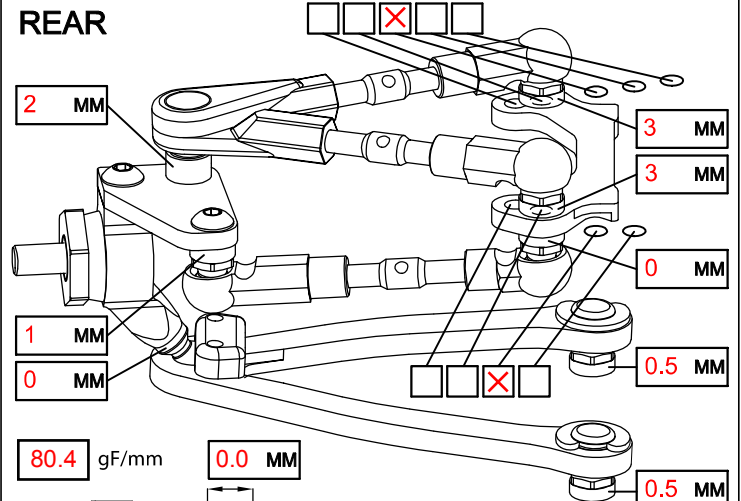

CAMBER ANGLE / ° **-1.5**
 CASTER ANGLE / ° **5 (2 mm)**
 TOE ANGLE / ° **-3**
 RIDE HEIGHT / MM **5.2**
 DOWNSTOP / MM **5.2**
 UPSTOP / MM **max**

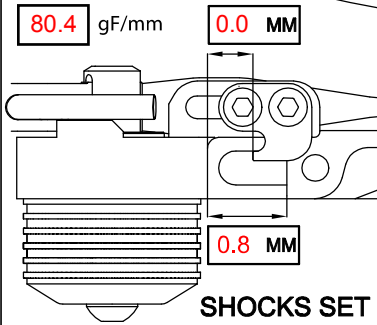

SHOCKS SET

STABILIZER Ø / MM **1.0**
 LOW ARM STD
 STEERING ARM STD
 WHEEL SPACER / MM
 REAR DRIVE BALL DIFF GEAR DIFF
 DIFF SET LOOSE MEDIUM TIGHT OIL # **650 MM**
 DOGBONE DRIVE BUSHING C-DRIVE BB EVD

SPRING STD
 DAMPER STD
 ACTION SYM. ASYM.
 SRS/RHS ARR. I II

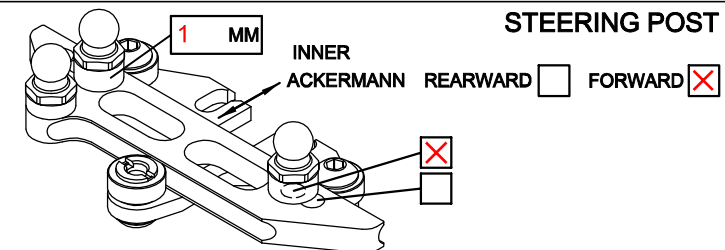
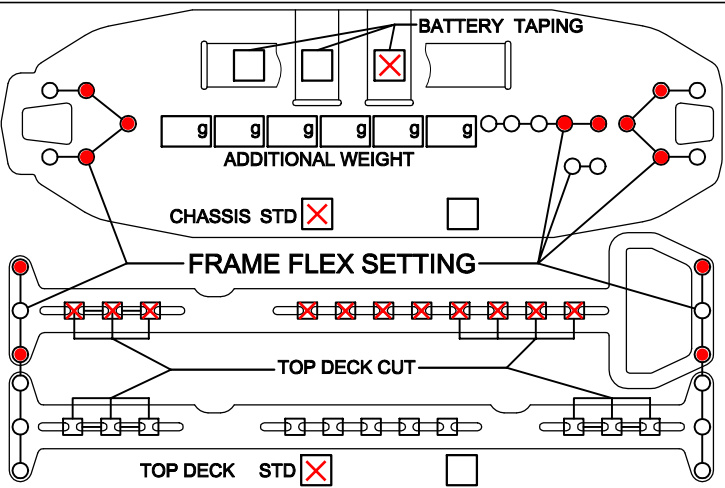

STEERING POST

FL	FR	RL	RR	TIRES	FRONT	REAR
				BRAND	Sorex 36	Sorex 36
				INSERTS	SY	SY
				WHEELS	XG	XG
				ADDITIVE	Rheinard	Rheinard

MOTOR LAYOUT LONG. TRANS.
 SERVO LAYOUT LEFT RIGHT
 ESC LAYOUT LEFT RIGHT
 BAT. LAYOUT R1 R2 F1 F2
 SPUR **89** PINION **40**
 FINAL DRIVE RATIO **4.63**
 BODY **SRC Kruzer**
 MOTOR **SP V3 13.5**
 SERVO **Sanwa**
 ESC **SP Cirtix**
 BATTERY **Orca**
 RECEIVER **Sanwa**
 MOTOR OFFSET / MM
 WING **MR33**

BEST LAP TIME **16"738** QUALIF. / FINAL POSITION **1** / 1

ESC SETTING **9-1-2**

COMMENTS / IMPRESSIONS

CONTACT realdamon@libero.it