

# SET-UP SHEET

# XRAY T3.11

RACE	17.5 stock Touring Car		
TRACK	Hobbytown USA		
NAME	Todd Steever		
CITY / COUNTRY			
CONTACT			

DATE	TEMPERATURE / °F or °C	AIR	TRACK
QUALIFYING POSITION	BEST LAPTIME /sec	FINAL POSITION	RACE LENGTH /minutes

TRACK CONDITION	<input checked="" type="checkbox"/> CARPET	<input type="checkbox"/> ASPHALT	
	<input type="checkbox"/> TECHNICAL	<input type="checkbox"/> FAST	
TRACTION	<input checked="" type="checkbox"/> LOW	<input type="checkbox"/> MEDIUM	<input type="checkbox"/> HIGH

FRONT	REAR
TRANSMISSION	

FRONT PULLEY	38	38	REAR PULLEY
DIFE			
<input type="checkbox"/> LOOSE	<input type="checkbox"/> MEDIUM	<input type="checkbox"/> LOOSE	<input type="checkbox"/> MEDIUM
<input type="checkbox"/> TIGHT	<input type="checkbox"/> TIGHT	<input checked="" type="checkbox"/> MEDIUM	<input type="checkbox"/> TIGHT
ONE WAY DIFFERENTIAL	<input type="checkbox"/> YES	MIDDLE ONE WAY PULLEY	
SOLID ONE WAY DIFE	<input type="checkbox"/> YES		
SOLID AXLE	<input checked="" type="checkbox"/> YES	FIXED	<input checked="" type="checkbox"/> ONE-WAY

PINION / T	39	SPUR GEAR / T	104
FINAL DRIVE RATIO	5.07	ROLLOUT	0.00

FRONT	REAR
<input type="checkbox"/> ALU	<input checked="" type="checkbox"/> PLASTIC
SHOCKS	
XRAY SPRINGS	
#308393 Super Soft	<input type="checkbox"/> YELLOW (D=1.4) 14 lb
#308394 Soft	<input type="checkbox"/> BLUE-GREEN (D=1.5) 15 lb
#308395 Soft Medium	<input type="checkbox"/> WHITE (D=1.5) 17.5 lb
#308385	<input type="checkbox"/> LIGHT-BLUE (D=1.6) 20 lb
#308396 Medium	<input type="checkbox"/> BLUE (D=1.6) 22.5 lb
#308386	<input type="checkbox"/> DARK-BLUE (D=1.7) 25 lb
#308396	<input type="checkbox"/> VIOLET (D=1.7) 28 lb
#308387	<input type="checkbox"/> LIGHT-PURPLE (D=1.8) 30 lb
#308397 Medium Hard	<input type="checkbox"/> PURPLE (D=1.8) 33 lb
#308388	<input type="checkbox"/> LIGHT-RED (D=1.9) 35 lb
#308398 Hard	<input type="checkbox"/> RED (D=1.9) 38 lb

#308373	<input type="checkbox"/> C.2.2	<input checked="" type="checkbox"/>
#308374	<input type="checkbox"/> C.2.4	<input type="checkbox"/>
#308375	<input type="checkbox"/> C.2.6	<input type="checkbox"/>
#308376	<input type="checkbox"/> C.2.8	<input type="checkbox"/>
#308377	<input checked="" type="checkbox"/> C.3.0	<input type="checkbox"/>
#308378	<input type="checkbox"/> C.3.2	<input type="checkbox"/>
#308379	<input type="checkbox"/> C.3.4	<input type="checkbox"/>

350	OTHER SPRING	350		
	OIL / CST			
	LENGTH /mm			
	PRELOAD /mm			
	REBOUND %			
<input checked="" type="checkbox"/> YES	<input type="checkbox"/> NO	FOAM INSERTS	<input checked="" type="checkbox"/> YES	<input type="checkbox"/> NO
<input type="checkbox"/> YES	<input checked="" type="checkbox"/> NO	O-RING ON SHAFT	<input type="checkbox"/> YES	<input checked="" type="checkbox"/> NO

<input type="checkbox"/> OPENED	<input checked="" type="checkbox"/> CLOSED
HOLES IN PISTON	

1.4	THICKNESS/mm	ANTI-ROLL BAR	THICKNESS/mm	1.2
-----	--------------	---------------	--------------	-----

Muchmore 28	TIRES	Muchmore 28		
	DIAMETER /mm			
	INSERTS			
Paragon FX II	ADDITIVE	Paragon FX II		
FRONT LEFT	FRONT RIGHT	TREATED AREA	REAR LEFT	REAR RIGHT

WHEELS		
S	M	H
	HARDNESS	

MOTOR	LRP x12	TIMING	Stock	
ROTOR		ARMATURE	17.5	
ESC	Tekin RS Pro	BATTERIES	500mah 40c	
BRUSHLESS	PROGRAM 3	PUNCH 0	INITIAL BRAKE 6	AUTO BRAKE 30%
BODY	Mazda Speed 6	WING	Back	

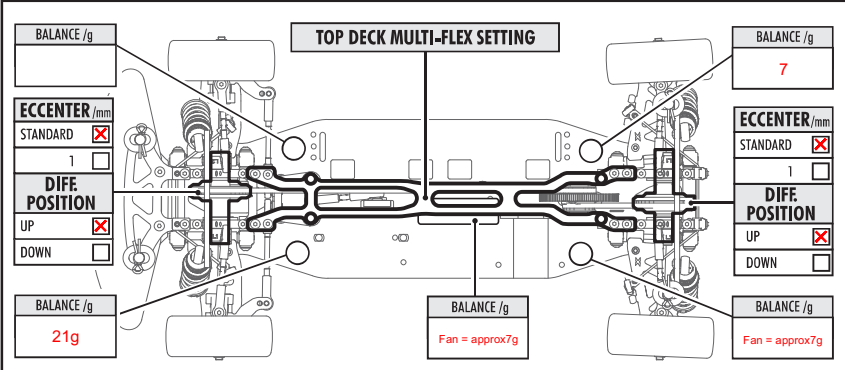
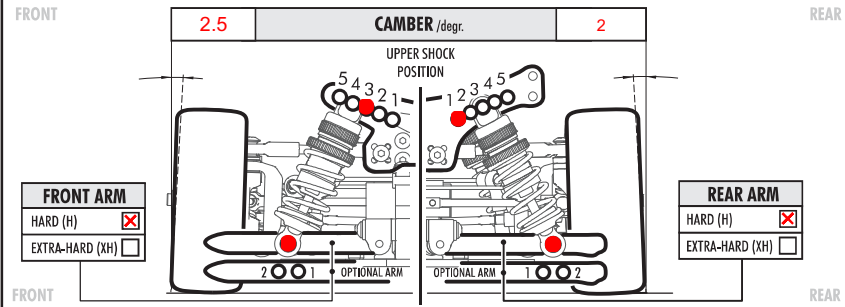
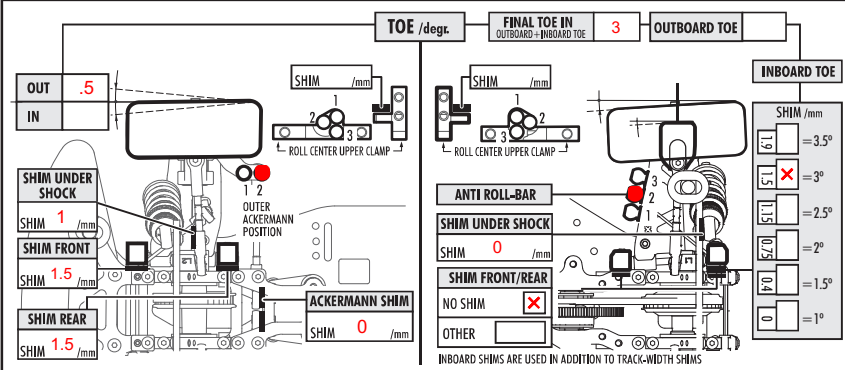
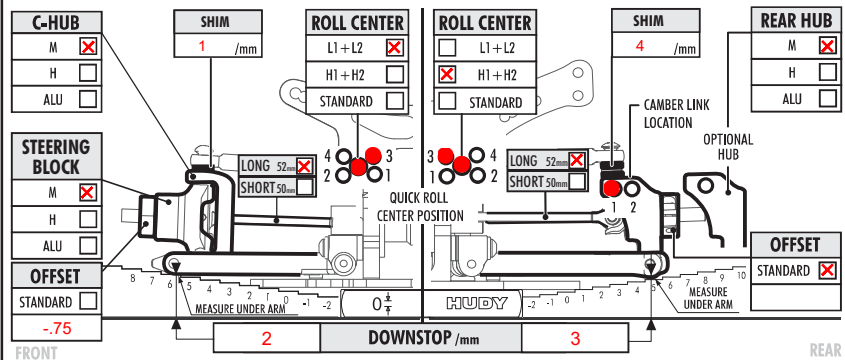
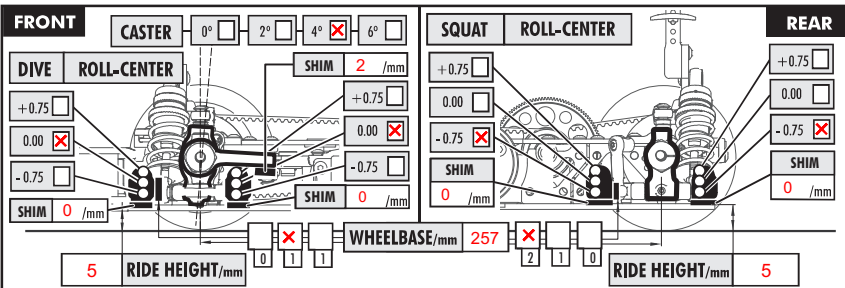

14g Weight added to front bumper to even out the weight distribution front to rear.  
 Downstops reflect droop settings  
 Cut top deck to mimic 2012 top deck flex