

Front	Suspension Geometry	Rear
	Outer Arm Mount Insert	
	Outer Mount Shims	
	Inner Arm Mount Insert	
	Inner Mount Shims	
	Anti-Roll Bar	

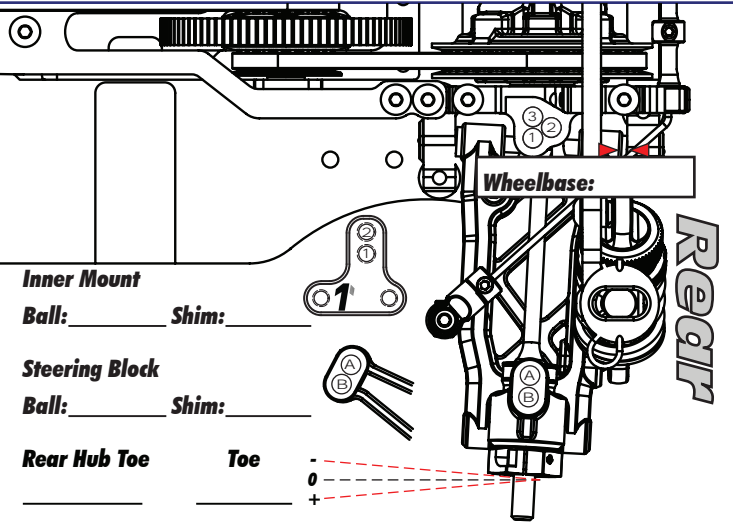

Shocks		
	Oil	
	Piston	
	Rebound	
	Spring	

Differentials		
	Type	
	Setting	
	Cam Position	
	Belt Tension Number	

Tires		
	Type	
	Tire Diameter	
	Insert & Wheel	
	Additive & Amount	

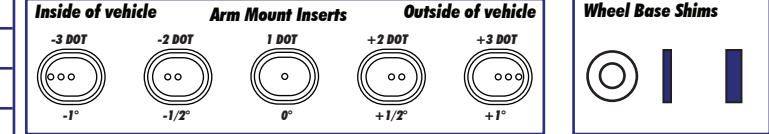
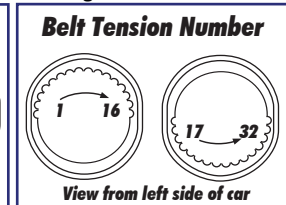
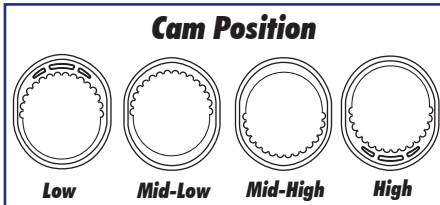
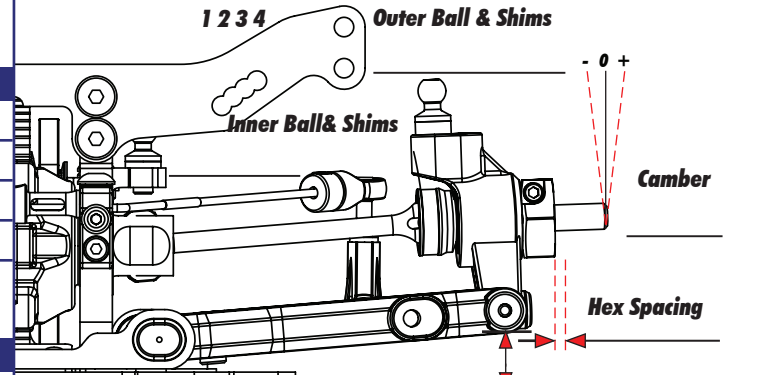
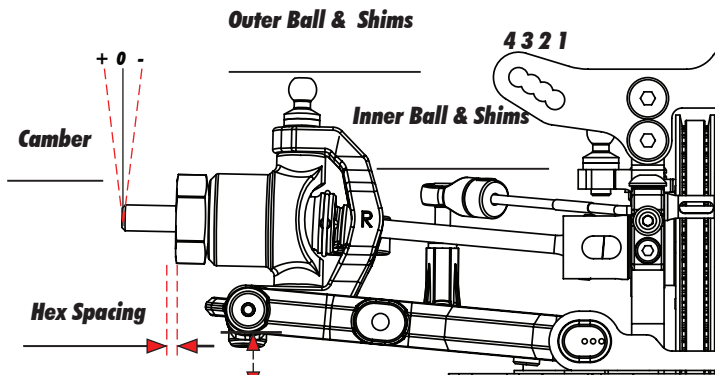

Chassis	Top Plate
Motor	Gearing
	/

Transmitter	Speed Control
Turning Circle: _____	E.S.C. Type: _____
Steering Expo: _____	E.S.C. Settings: _____
Brake E.P. : _____	Software Version: _____
Throttle Expo: _____	
Battery & Placement	Body & Wing