

Name: Mike Haynes  
 City: \_\_\_\_\_ State: \_\_\_\_\_  
 Country: \_\_\_\_\_  
 E-mail: \_\_\_\_\_  
 Phone: \_\_\_\_\_

Date: 11/27/05 Event: US Indoor Champs  
 Track: \_\_\_\_\_  
 Qualified: \_\_\_\_\_ Finish: \_\_\_\_\_  
 Best Lap Time / sec: \_\_\_\_\_ Avg. Lap Time / sec: \_\_\_\_\_  
 Note: \_\_\_\_\_

Track Conditions		
Time	Air Temp	Track Temp
: am/pm	F or C	F or C
<input type="checkbox"/> Indoor	<input type="checkbox"/> Tight	Race Length (min)
<input type="checkbox"/> Outdoor	<input type="checkbox"/> Open	
<input type="checkbox"/> Asphalt	<input type="checkbox"/> Sealed	<input type="checkbox"/> Low Bite
<input type="checkbox"/> Carpet	<input type="checkbox"/> Smooth	<input type="checkbox"/> Med Bite
<input type="checkbox"/> Concrete	<input type="checkbox"/> Rough	<input type="checkbox"/> High Bite

## Front Suspension

Toe  In  Out 1.5°  
 Camber  -  + 1°  
 Ride Height 4.75 mm  
 Kick  
 Castor  Anti-Dive  
 Small (.035) shim = 1°  
 # Shims \_\_\_\_\_ .050 # Shims \_\_\_\_\_

**Front Shocks**  
 Oil 60  
 Brand AE  
 Piston 60  STD  Drilled  
 Spring 60  
 Bladder white  
 Above Bladder 2 white o rings

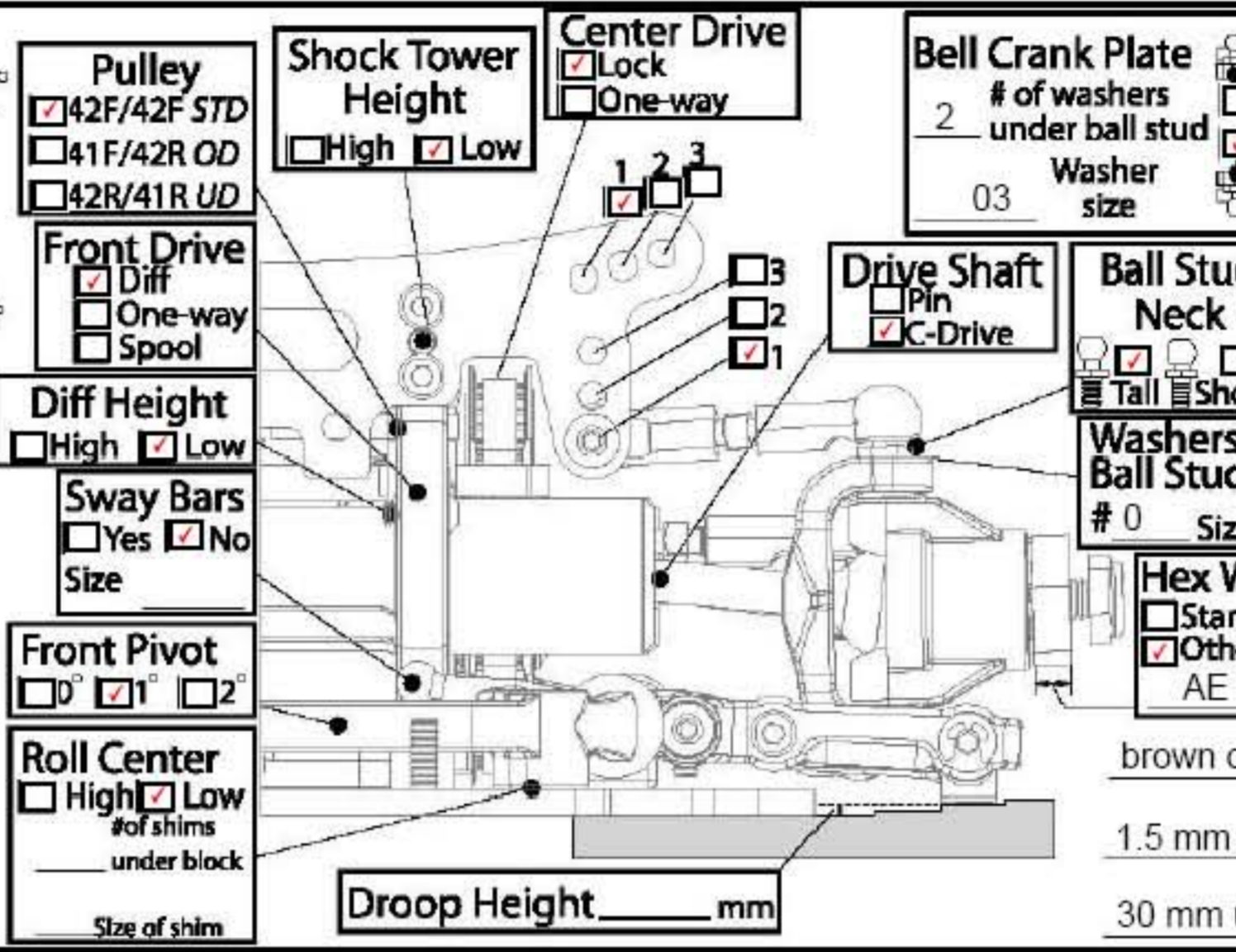
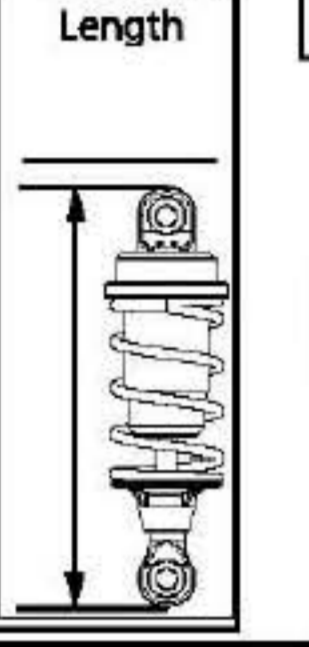

**Bump Steer**  
 # of washers under spindle 2  
 Size of Washers 03

**Arm Spacing**  
 Forward  Middle  Back

**Notes:**  
 brown grease in diff  
 1.5 mm droop  
 30 mm uptravel to axle

## Rear Suspension

Toe  In  Out 2°  
 Ride Height 4.75 mm  
 Camber  -  + 1°  
 Hub  0°  1°  1/2°  2°

**Rear Shocks**  
 Oil 40  
 Brand losi  
 Piston 57  STD  Drilled  
 Spring 25  
 Bladder white  
 Above Bladder \_\_\_\_\_

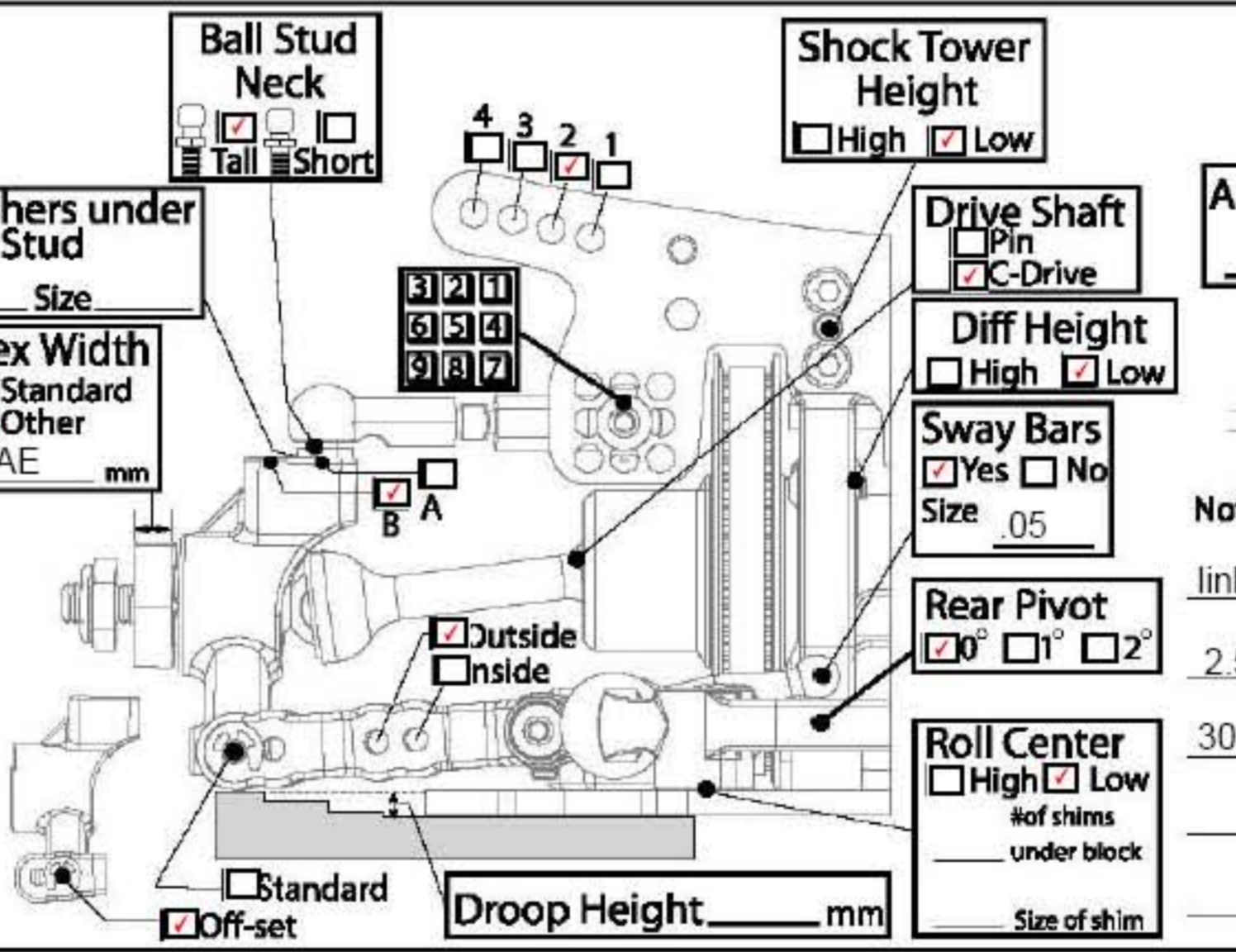
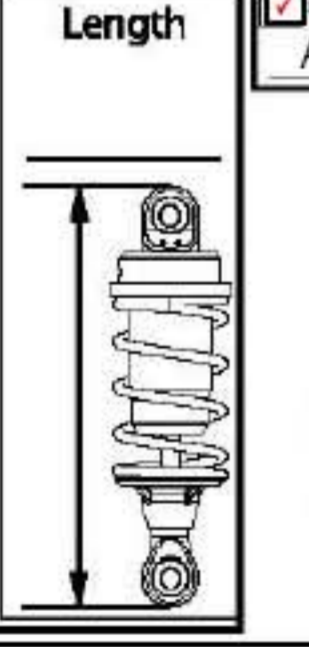

**Anti-Squat**  
 Shim Size \_\_\_\_\_

**Pro-Squat**  
 Shim Size .050

**Notes:**  
 link # 7b  
 2.5 mm droop  
 30 mm uptravel to axle

**Body** Parma Alfa  
**Wing** Standard  
 FR Body Hole 3  
 RR Body Hole 7  
 5th Body Hole --  
 Body Height --

**Motor** Checkpoint  
 Turns 7x1  
 Brushes Infinity  
 Springs Gold  
 Timing 14

**Spur Gear** 128  
**Pinion Gear** 24  
 Spur ÷ Pinion = \_\_\_\_\_ (Ratio)  
 S/P x 1.83 = 9.76 (Ratio)  
 Roll Out 18.19

**Servo** 94768  
**ESC** QC2  
**Receiver** 302f  
**Battery** Surge 3800  
**Transponder Location** near RX

**Weight Placement**

Vehicle Weight \_\_\_\_\_

Tires:	Brand	Compound	Insert	Wheel	Additive	Tire Warmers
Front:	Speedmind	Hybrid 3		56.5		<input type="checkbox"/> YES <input checked="" type="checkbox"/> NO
Rear:	Speedmind	35		56.4		

Temp F or C

NOTES: