

Front Suspension:

Ride Height: _____
 Camber: _____
 Toe: _____
 Anti-Roll Bar: _____
 Arm Type: _____
 Tower Type: _____
 Wheel Hex: _____
 Steering Block: _____
 Caster Block Insert: _____
 Bulkhead Type: _____
 Kick-Up Angle: _____
 Notes: _____

Bump Steer Spacing: _____
 Steering Plate: _____
 Steering Stop Spacing: _____
 Caster Block Spacing: _____
 Axle Height:
 +3
 +2
 +1
 +0

Ball Stud Spacing: _____
 Steering Bellcrank Position:
 Up
 Down
 Ball Stud Spacing: _____

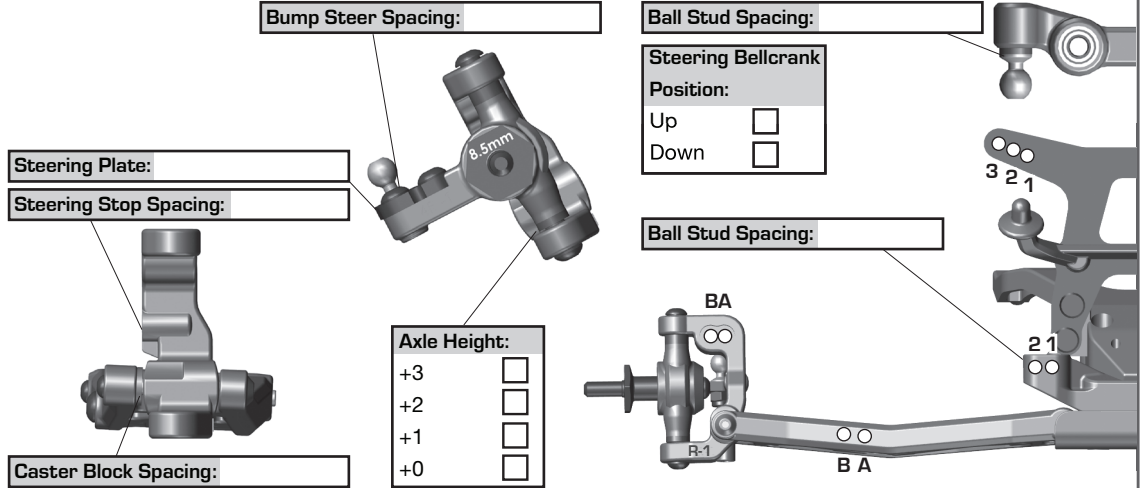

Rear Suspension:

Ride Height: _____
 Camber: _____
 Anti-Roll Bar: _____
 Arm Type: _____
 Tower Type: _____
 Arm Spacing: _____
 Wheel Hex: _____
 Shock Mounting Position:
 Front of Arm Rear of Arm
 Hub Spacing: Fwd Mid Back
 CVA Bone Length: _____
 CVA Axle Type: _____
 Notes: _____

C Mount:
 Aluminum Brass
 D Mount:
 Aluminum Brass

Axle Height:
 ▼0 3 ▲ +3
 ▼1 2 ▲ +2
 ▲1 2 ▼ +1
 ▲0 3 ▼ +0

Camber Link Spacing: _____
 Ball Stud Spacing: _____
 Ball Stud Spacing: _____

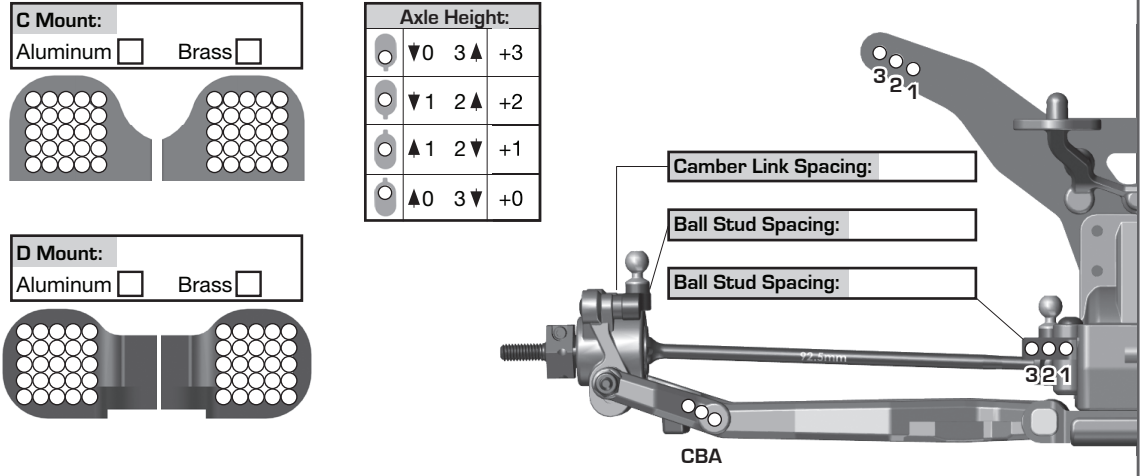

Electronics:

Radio: _____ Servo: _____
 EPA: Throttle: _____ % Brake: _____ %
 ESC: _____
 ESC Settings: _____
 Motor / Wind: _____ Timing: _____
 Pinion: _____ Spur: _____
 Battery: _____
 Battery Position:
 Back 1 2 3 4 5 Forward
 Battery Weight: _____

Drivetrain:

Transmission: _____
 Laydown: Layback:
 Differential: _____ Ball Diff:
 Height: _____ Gear Diff:
 Diff Setting: _____
 Notes: _____

Slipper Clutch:

Type: _____
 # of Pads: _____
 Setting: _____

Shocks:

	Front	Rear
Piston:	_____	_____
Thickness:	_____	_____
Fluid:	_____	_____
Spring:	_____	_____
Limiters:	Int: _____ Ext: _____	Int: _____ Ext: _____
Stroke:	_____	_____
Eyelet Length:	_____	_____
Cup Offset:	_____	_____
Notes:	_____	_____



Track Info:

Size: Small Medium Large Extra Large
 Surface: Dirt Carpet Astroturf Multi Surface
 Traction: Low Medium High Very High
 Moisture: Dry Damp Wet
 Condition: Indoor Outdoor Dusty Hard Packed
 Bumpy Grooved Smooth Loamy
 Temperature: Ambient: _____ Track: _____
 Notes: _____
 Vehicle Comments: _____

Tires:

Front Tires: _____
 Front Compound: _____
 Front Insert: _____
 Rear Tires: _____
 Rear Compound: _____
 Rear Insert: _____
 Wheel (F/R): _____
 Notes: _____

Body, Weight:

Body: _____
 Body Height: _____
 Servo Weights: _____
 Electronic Weights: _____
 Total Vehicle Weight: _____
 Notes: _____