

Name: \_\_\_\_\_ Date: \_\_\_\_\_ Event: \_\_\_\_\_

Track: Indoor  Outdoor  Size: Small  Medium  Large  Traction: Low  Med  High

Surface: Smooth  Bumpy  Rutted  Type: Loose/Loamy  Hard Pack  Blue Groove  Clay

Bumpsteer/Ackerman/Servo Saver/Steering Stop: \_\_\_\_\_ Condition: Dusty  Dry  Wet  Muddy

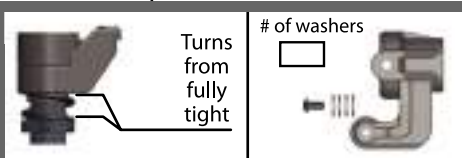
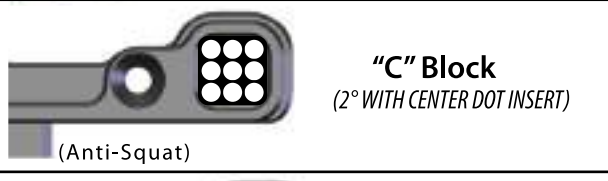
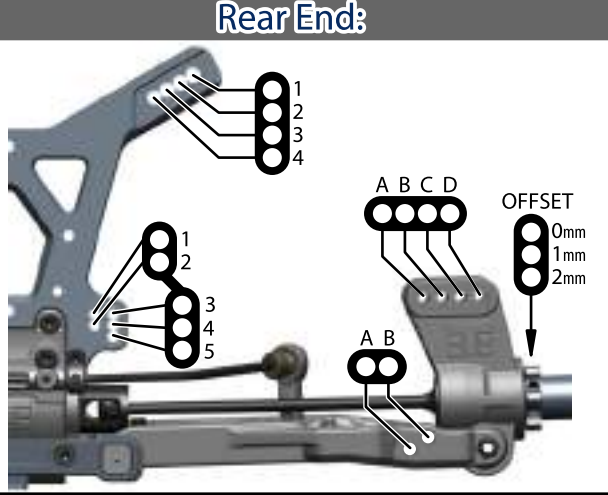
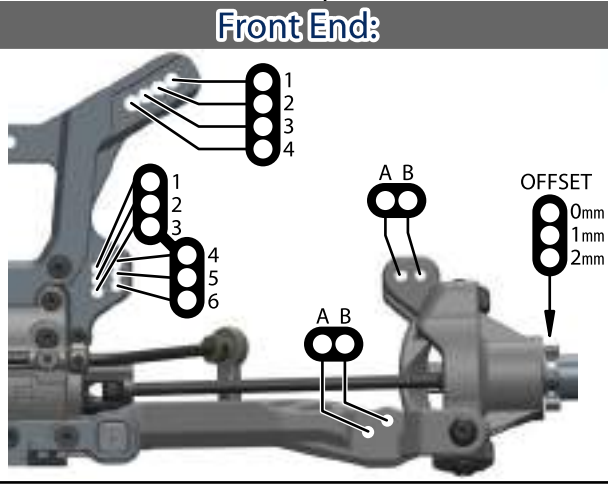
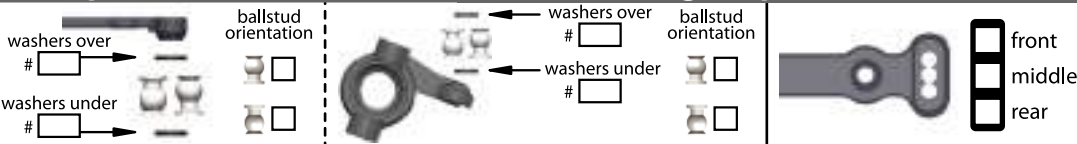

### Suspension:

	FRONT	REAR
RIDE HEIGHT		
CAMBER		
CASTER		
SWEEP		
KICK UP		
ANTI-SQUAT		
TOE (in/out)		
SWAY BAR		
SHOCK LENGTH (DROOP)		

### Body/Wing:

BODY MAKE	
WING MAKE	

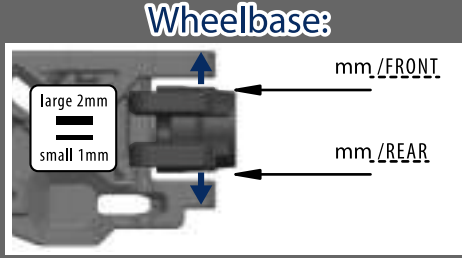
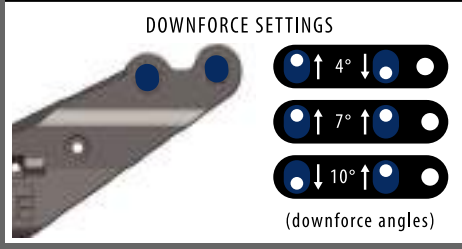
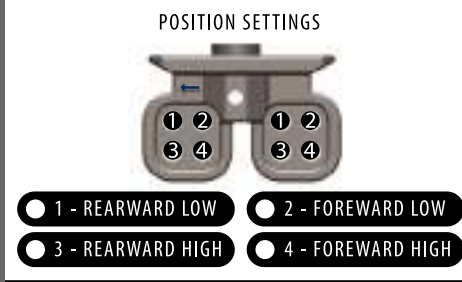

### Shocks:

	FRONT	REAR
OIL		
BRAND		
PISTON		
SPRING		
REBOUND	%	%
STD/EMUL/VENT		
NOTES:		

### Tires/Wheels:

	FRONT	REAR
BRAND/TREAD		
COMPOUND		
INSERT		
WHEEL		
NOTES:		

### Differential Oil:

	FRONT	CENTER	REAR

### Equipment:

ENGINE/PIPE:	/	
PLUG:		
FUEL:		
RX BATT:		
SERVOS:	(steering) / (throttle/brake)	

### Drivetrain:

CLUTCH/SPUR:	/	(teeth)
CLUTCH SHOES:		
CLUTCH SPRINGS:		
BRAKE BIAS:	(front) % / (rear) %	

### Chassis Braces:

Center  Left Rear  Right Rear

(front brace is always recommended)

Notes: