

Name: Mo Denton

Date:

Event/Track:

Track Conditions: Outdoor Indoor Wet Dry High Bite Low Bite Rough
 Smooth Hard Packed Loose/Loamy Blue Groove

Bumpsteer/Ackerman/Servo Saver/Steering Stop:

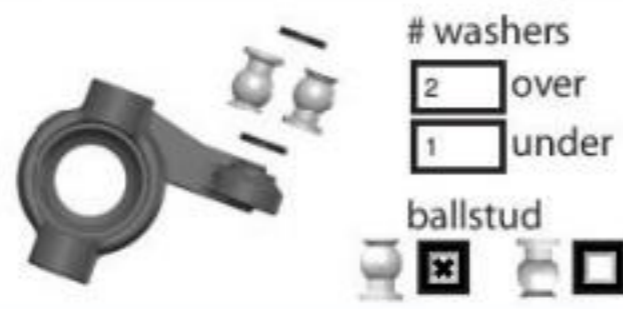

Front End:

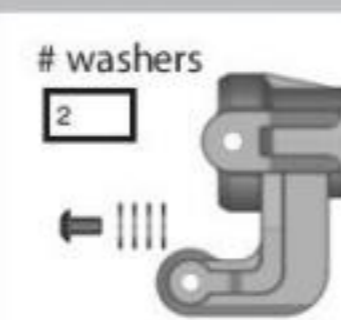
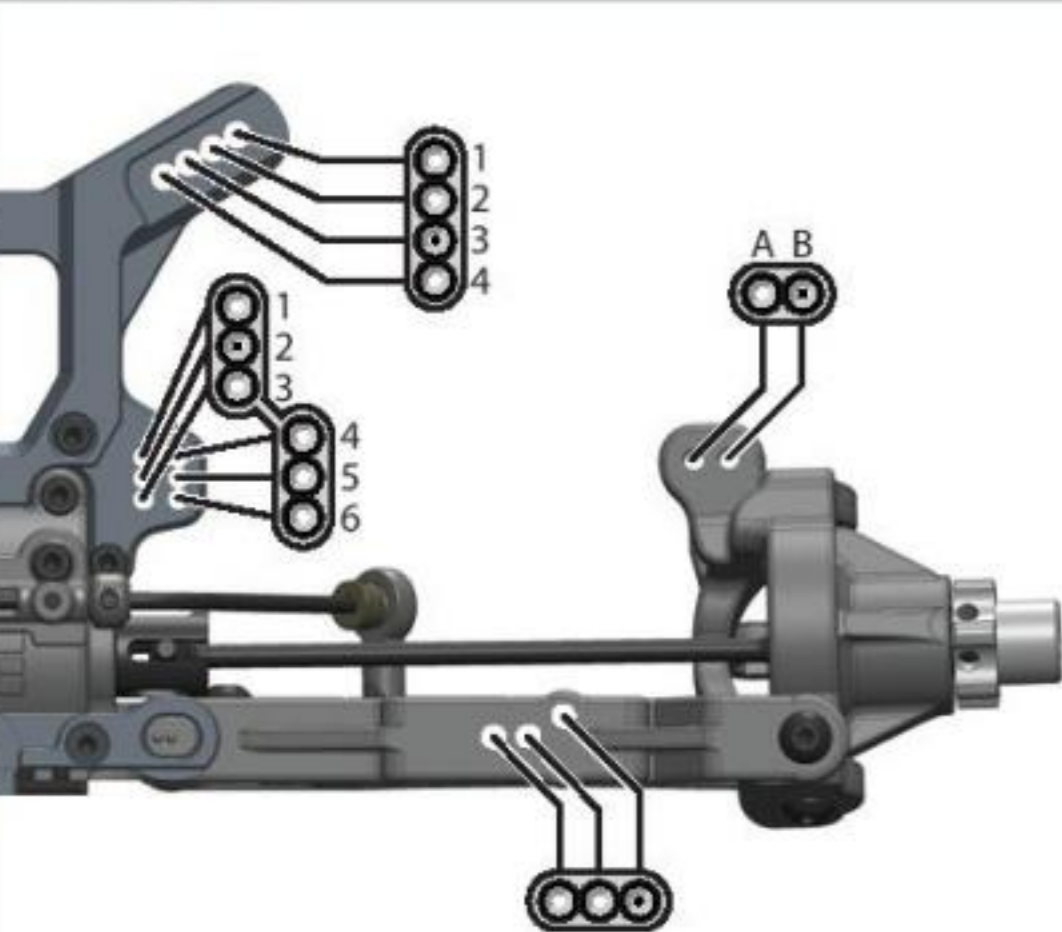

Suspension:

	FRONT	REAR
RIDE HEIGHT:	27	27
TOE (in/out):	1	3
CAMBER:	-1	-2
CASTER:	stk Deg°	
SHOCK LENGTH (DROOP):	104	121
SWAY BAR:	2.6	2.5

NOTES:

Body/Wing:

BODY:	stk
WING:	stk

Front Outer (Sweep)

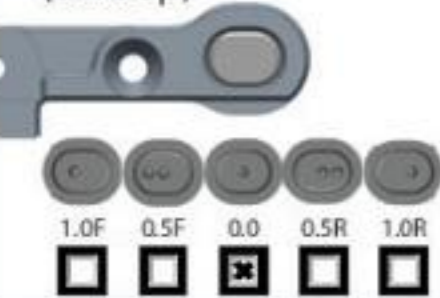

Front Inner (Kick Up)



Rear End:

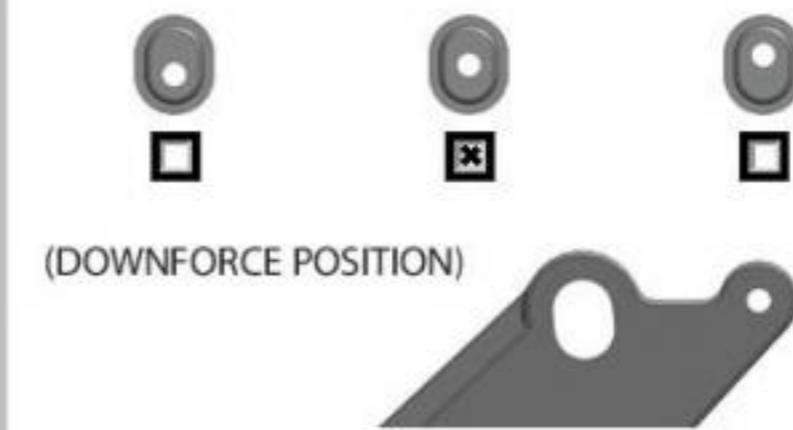
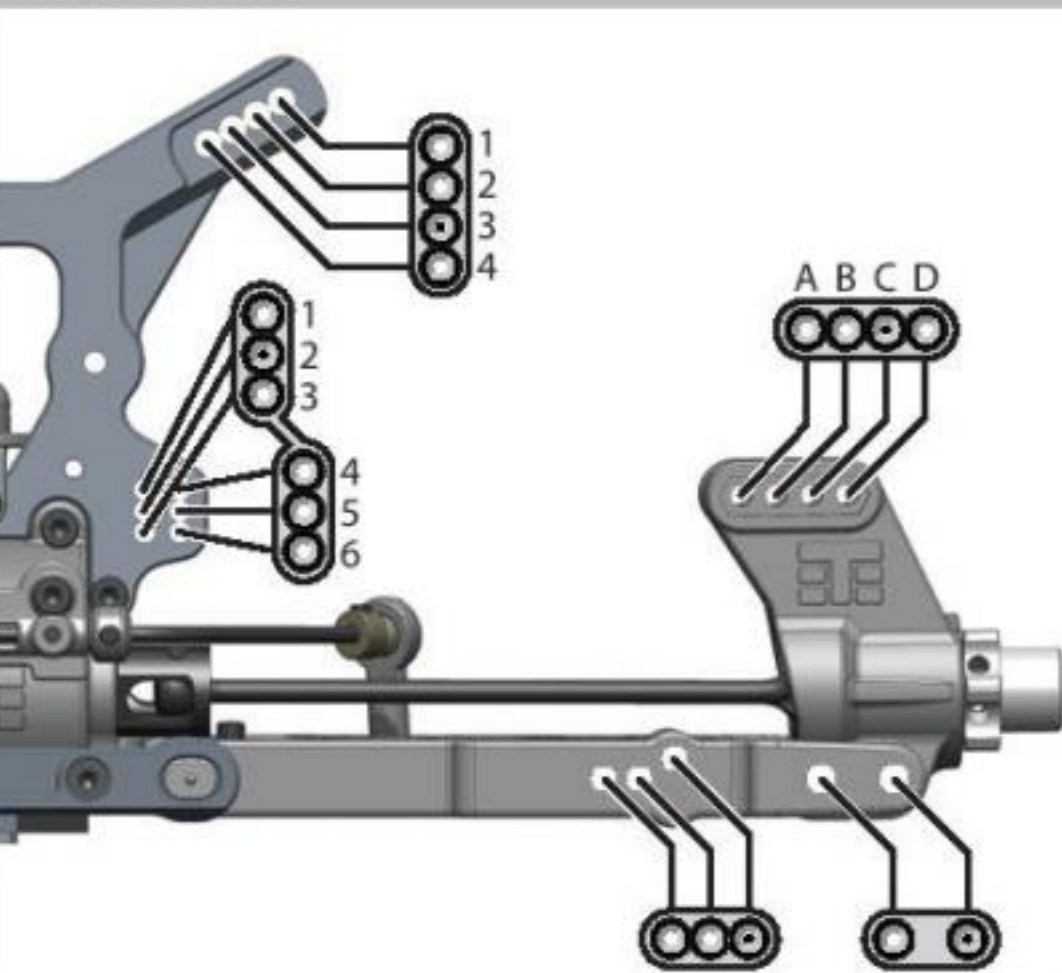

Wheelbase:

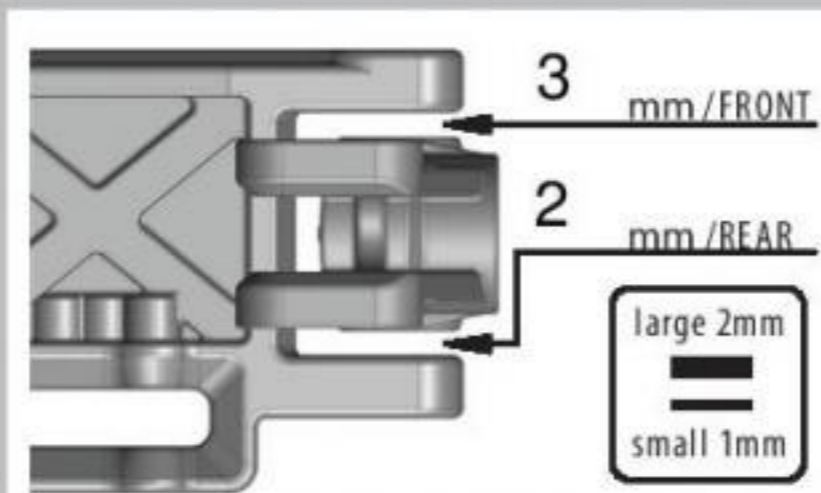

Notes:

LRC rear block

losi steel flywheel

Rear Outer (Toe In)



Rear Inner (Anti-Squat)



	FRONT	REAR
STD/EMUL/VENT:	std	std
PISTON:	10h 1.2	10h 1.2
OIL:	600	500
BLADDER:	grey	grey
REBOUND:	50 %	50 %
SPRING:	pink	red

NOTES:

Tires / Wheels:

	FRONT	REAR
BRAND:	proline	proline
TREAD:	blockade	blockade
COMPOUND:	M3	M3
INSERT:	AKA red	AKA red
WHEEL:	proline v2	proline v2

NOTES:

Differential Oil:

	FRONT	CENTER	REAR
	5k	5k	4k

NOTES:

Equipment:

ENGINE:	OS spec 2
PIPE:	OS 2090
PLUG:	p3
FUEL:	Byrons
RX BATT:	protek Lipo
SERVOS:	steering Savox2274 / throttle/brake savox2274

Drivetrain:

CLUTCH/SPUR:	stk / 15 (teeth)
CLUTCH SHOES:	losi carbon/AL
CLUTCH SPRINGS:	green/gold
ENGINE POSITION:	Front <input checked="" type="checkbox"/> Rear <input type="checkbox"/>
BRAKE BIAS:	front 60 % rear 40 %

Chassis Braces:

Center Rear Left Rear Right