

Name **Andy Moore**

Date **20-23 feb 2014** Event **TITC 2014**

Temp **Air 34** Track

Track **HUGE RC**

Track Condition Indoor Tight Smooth Wet Low Bite High Bite
Outdoor Open Rough Dusty Med Bite Other

Front

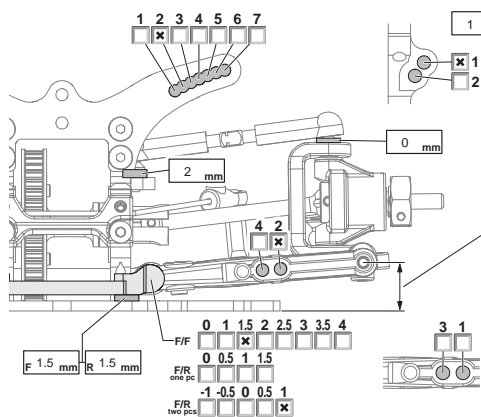

Ride Height **5** mm

Camber Angle **2** °

Droop **9** mm Sway bar **1.4** mm

Toe Angle **-1** ° Caster Angle **4** °

Wheel Spacer **0.5** mm Wheel Hub **4** mm

Shocks

	Front	Rear
Piston	3x1.1	3x1.1
Oil wt.	450	450
Bladder	std	std
Spring	6542_blue	6542_blue
Shock Length	64 mm	64 mm

Rear

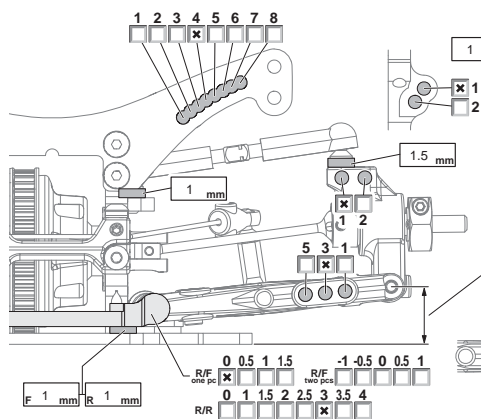

Ride Height **5.2** mm

Camber Angle **2** °

Droop **8** mm

Sway bar **1.2** mm

Wheel Spacer **0.5** mm Wheel Hub **4** mm

Tires

	Front	Rear
Brand	RIDE	RIDE
Compound	34	34
Insert		
Wheel		
Tire Treatment	Mighty V3	Mighty V3

Chassis

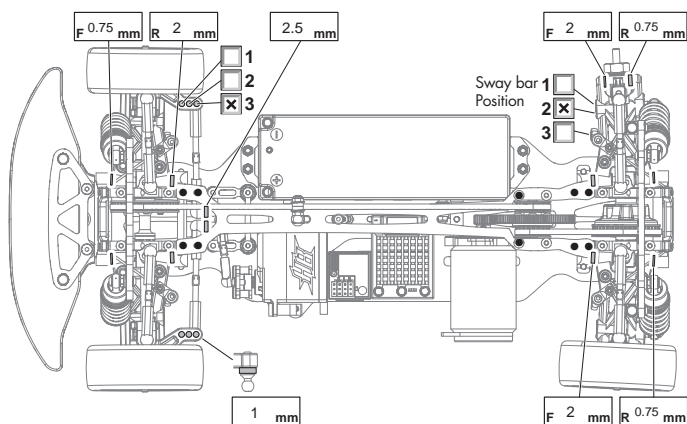

v2 knuckle, Pro 4 arms, 2.5mm top deck, new rebuildable dcj, tcx motor mount/top deck raised 0.5mm

Note

Diff

	Front	Rear
Type	spool	gear_diff
Note		7000

Motor

Motor	Hobbywing 4.5	Spur Gear	115
Battery	Moorspeed 6200	Pinion Gear	28
Body	Protoform LTCR	ESC	Hobbywing V3.1
Wing	Ride	Note	